

Lesson Twenty-Four

Romans 6:15-23

- 15) **Τί οὖν; ἀμαρτήσομεν, (ἀμαρτήσωμεν) ὅτι οὐκ ἐσμέν ὑπὸ νόμον, ἀλλ' (ἀλλὰ) ὑπὸ χάριν; μὴ γένοιτο.**
What therefore? shall we sin, (should we sin) because not we are under law, but (but) under grace? not may it happen.
- 16) **οὐκ οἴδατε ὅτι ᾧ παριστάνετε ἑαυτοὺς δούλους εἰς ὑπακοήν, δοῦλοι ἐστε ᾧ ὑπακούετε, ἥτοι ἀμαρτίας εἰς θάνατον, ἢ ὑπακοῆς εἰς δικαιοσύνην;**
not did you know that to whom you are presenting yourselves slaves for obedience, slaves you are to whom you are obeying, whether of sin for death, or of obedience for righteousness?
- 17) **χάρις δὲ τῷ θεῷ, ὅτι ἦτε δούλοι τῆς ἀμαρτίας, ὑπηκούσατε δὲ ἐκ καρδίας εἰς ὃν παρεδόθητε τύπον διδαχῆς·**
thanks now the to God, because you were slaves the of sin, you obeyed and out of heart into which you were delivered type of doctrine;
- 18) **ἐλευθερωθέντες δὲ ἀπὸ τῆς ἀμαρτίας, ἐδουλώθητε τῇ δικαιοσύνῃ.**
having become free and from the sin, you were enslaved the to righteousness.
- 19) **ἀνθρώπινον λέγω διὰ τὴν ἀσθένειαν τῆς σαρκὸς ὑμῶν· ὥσπερ γὰρ παρεστήσατε τὰ μέλη ὑμῶν δούλα τῇ ἀκαθαρσίᾳ καὶ τῇ ἀνομίᾳ εἰς τὴν ἀνομίαν, οὕτω(ς) νῦν παραστήσατε τὰ μέλη ὑμῶν δούλα τῇ δικαιοσύνῃ εἰς ἁγιασμόν.**
human I am speaking on account of the weakness the of flesh of you; as indeed for you presented the members of you slaves the to uncleanness and the to lawlessness for the lawless, in this way now present the members of you slaves the to righteousness for sanctification.

- 20) ὅτε γὰρ δούλοι ἦτε τῆς ἀμαρτίας, ἐλεύθεροι ἦτε τῇ
when for slaves you were the of sin, free you were the

δικαιοσύνη.
righteousness.
- 21) τίνα οὖν καρπὸν εἶχετε τότε ἐφ' οἷς νῦν ἐπαισχύνεσθε;
what therefore fruit you had then upon which now you are ashamed?

τὸ γὰρ τέλος ἐκείνων θάνατος.
the for end of those things death.
- 22) νυνὶ δὲ ἐλευθερωθέντες ἀπὸ τῆς ἀμαρτίας, δουλωθέντες δὲ
now and having become free from the sin, having been enslaved and

τῷ Θεῷ, ἔχετε τὸν καρπὸν ὑμῶν εἰς ἀγιασμόν, τὸ δὲ
the to God, you have the fruit of you for sanctification, the and

τέλος ζωῆν αἰώνιον.
end life eternal.
- 23) τὰ γὰρ ὀψώνια τῆς ἀμαρτίας θάνατος, τὸ δὲ χάρισμα τοῦ
the for wages the of sin death, the but gift the

Θεοῦ ζωὴ αἰώνιος ἐν Χριστῷ Ἰησοῦ τῷ κυρίῳ ἡμῶν.
of God life eternal in Christ Jesus the Lord of us.

Word Association Diagram

Romans 6:15-23

Verse 15

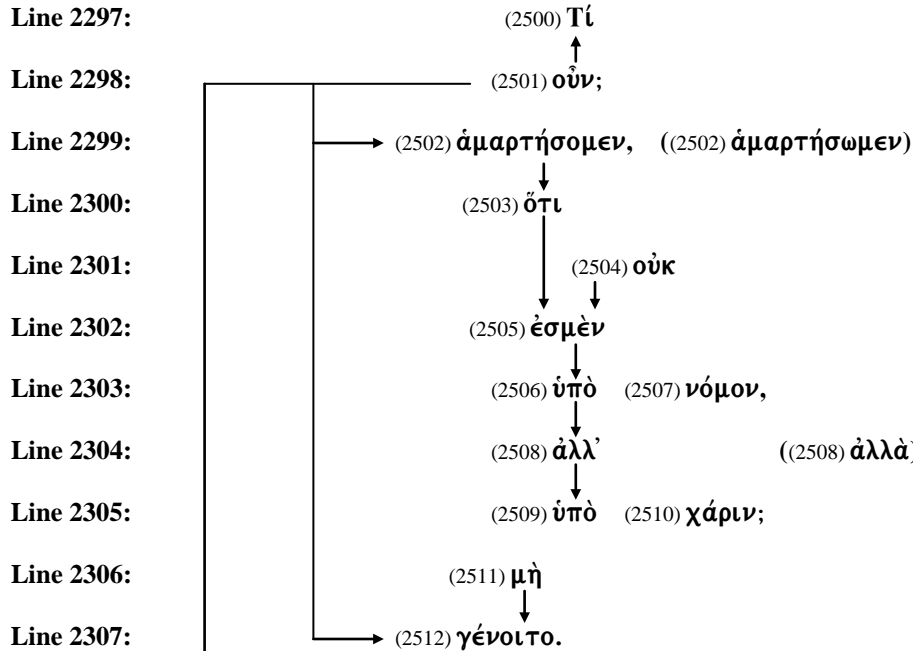

Verse 16

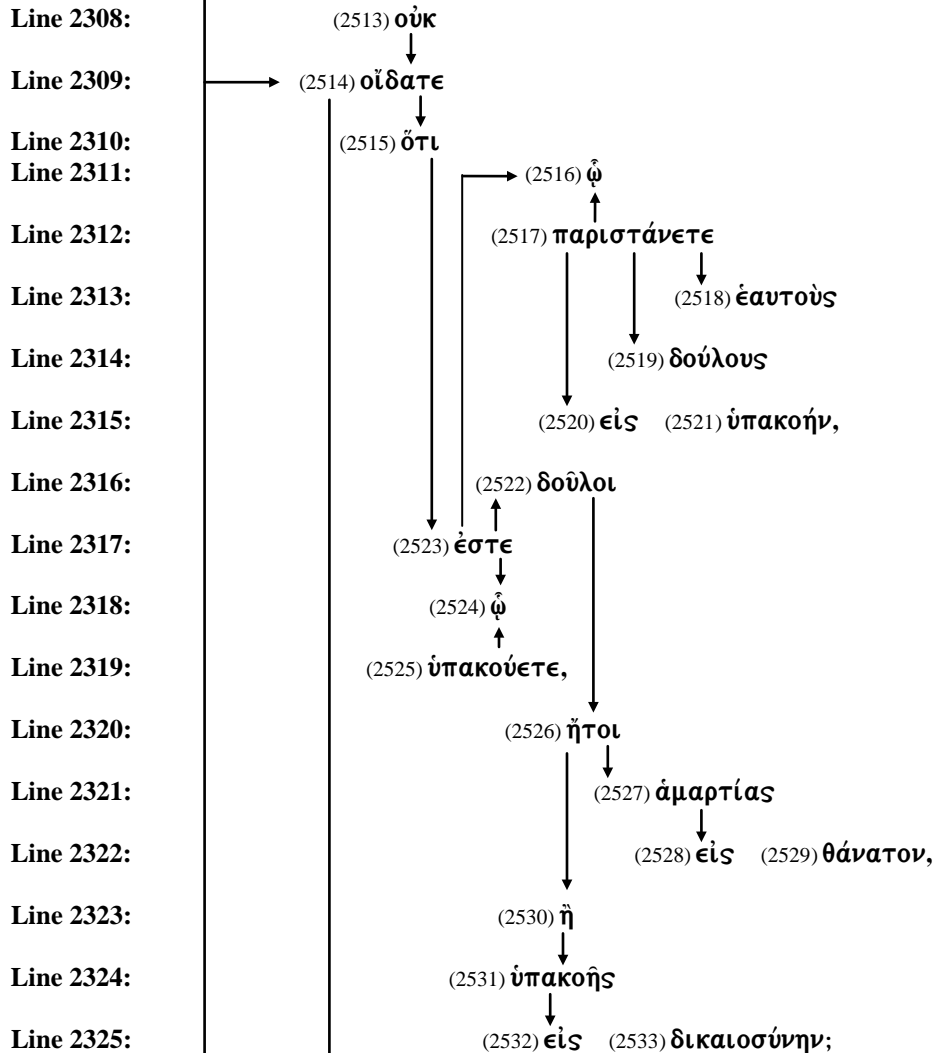

Verse 17

Line 2326:

Line 2327:

Line 2328:

Line 2329:

Line 2330:

Line 2331:

Line 2332:

Line 2333:

Line 2334:

Line 2335:

Line 2336:

Line 2337:

Line 2338:

Line 2339:

Line 2340:

Line 2341:

Verse 18

Line 2342:

Line 2343:

Line 2344:

Line 2345:

Line 2346:

Line 2347:

Line 2348:

Line 2349:

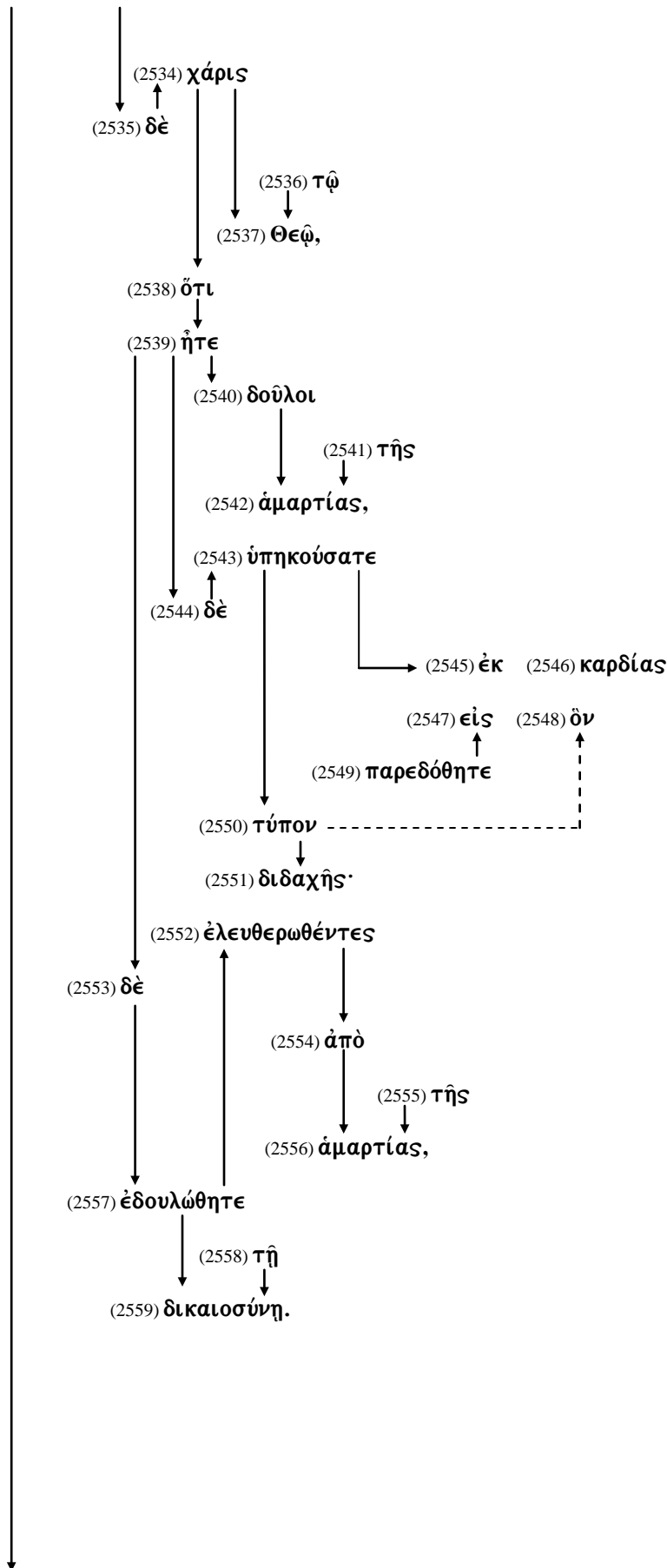

Word Association Diagram

Romans 6:15-23

Verse 19

Line 2350:

Line 2351:

Line 2352:

Line 2353:

Line 2354:

Line 2355:

Line 2356:

Line 2357:

Line 2358:

Line 2359:

Line 2360:

Line 2361:

Line 2362:

Line 2363:

Line 2364:

Line 2365:

Line 2366:

Line 2367:

Line 2368:

Line 2369:

Line 2370:

Line 2371:

Line 2372:

Line 2373:

Line 2374:

Line 2375:

Line 2376:

Line 2377:

Line 2378:

Line 2379:

Line 2380:

Line 2381:

Line 2382:

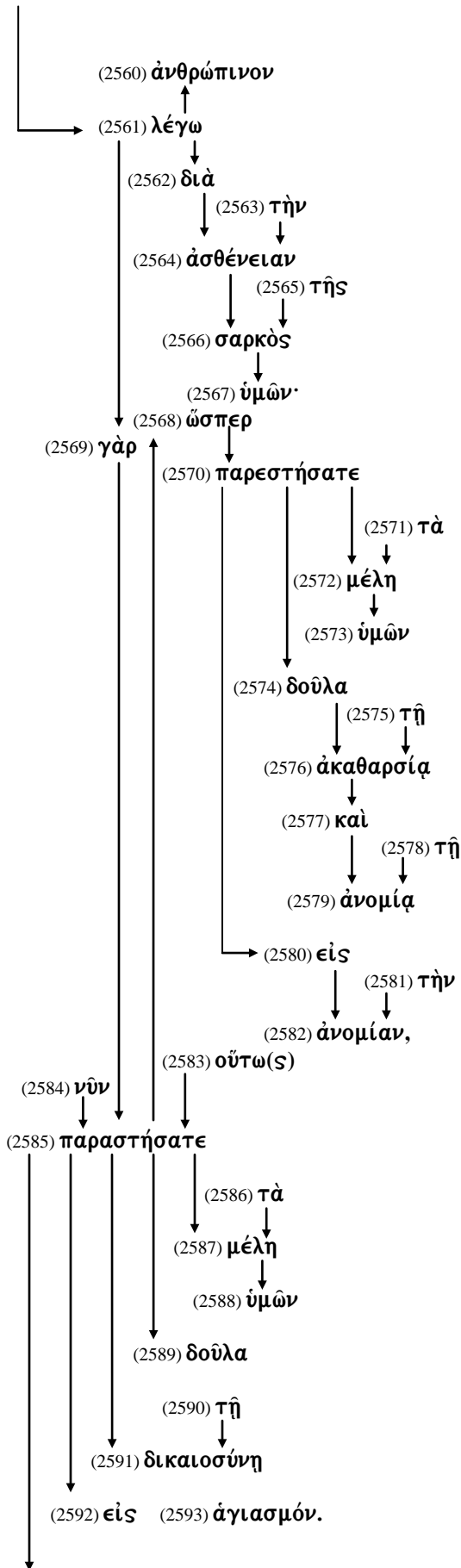

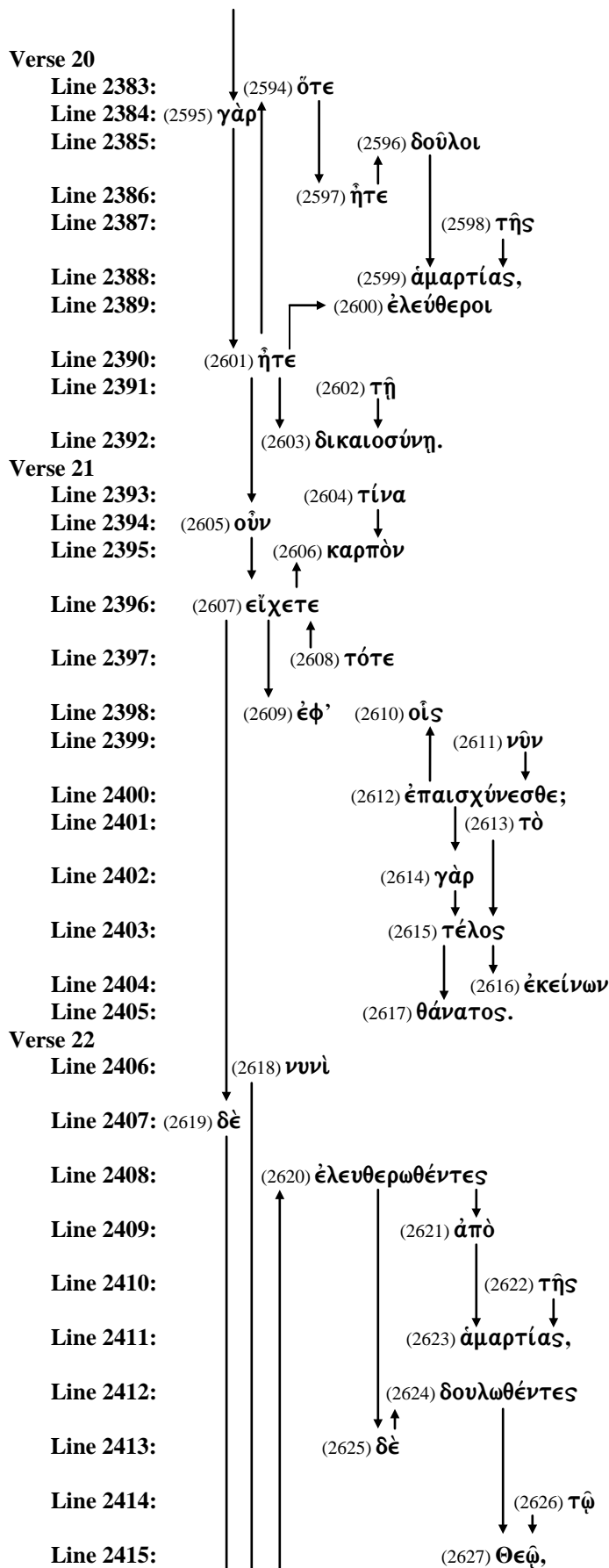

Word Association Diagram

Romans 6:15-23

Verse 22 (cont)

Line 2416: (2628) ἔχετε
 Line 2417: (2629) τὸν
 Line 2418: (2630) καρπὸν
 Line 2419: (2631) ὑμῶν
 Line 2420: (2632) εἰς (2633) ἁγιασμόν,
 Line 2421: (2634) τὸ
 Line 2422: (2635) δὲ
 Line 2423: (2636) τέλος =
 Line 2424: = (2637) ζωὴν
 Line 2425: (2638) αἰώνιον.

Verse 23

Line 2426: (2639) τὰ
 Line 2427: (2640) γὰρ
 Line 2428: (2641) ὀφώνια
 Line 2429: (2642) τῆς
 Line 2430: (2643) ἁμαρτίας
 Line 2431: (2644) θάνατος,
 Line 2432: (2645) τὸ
 Line 2433: (2646) δὲ
 Line 2434: (2647) χάρισμα
 Line 2435: (2648) τοῦ
 Line 2436: (2649) Θεοῦ
 Line 2437: (2650) ζωὴ
 Line 2438: (2651) αἰώνιος
 Line 2439: (2652) ἐν (2653) Χριστῷ (2654) Ἰησοῦ =
 Line 2440: (2655) τῷ
 Line 2441: = (2656) Κυρίῳ
 Line 2442: (2657) ἡμῶν.

I Romans 1:1-17
The Introduction

II Romans 1:18-11:36
The Doctrine of the Christian Faith

Romans 1:18-3:20
The Indictment: The Doctrine of Condemnation

Romans 3:21-5:21
The Imputation: The Doctrine of Justification

Romans 6:1-8:39
The Impartation: The Doctrine of Sanctification

Romans chapters 6-7 are systematically arranged around four questions:

- 1) **Romans 6:1**
- 2) **Romans 6:15**
- 3) **Romans 7:7**
- 4) **Romans 7:13**

Romans 6 The Power over Sin

Romans 6:1-14 The Principles of Sanctification

Romans 6:15-23 The Process of Sanctification

Romans 7 The Problem of the Flesh

Romans 7:1-6 The Precepts of Sanctification

Romans 7:7-13 The Perception of Sanctification

Romans 7:14-25 The Performance of Sanctification

Romans 8 The Provision of the Spirit

Romans 8:1-4 The Plan of Sanctification

Romans 8:5-11 The Procedure of Sanctification

Romans 8:12-17 The Product of Sanctification

Romans 8:18-25 The Patience in Sanctification

Romans 8:26-30 The Provision of Sanctification

Romans 8:31-39 The Position in Sanctification

Lesson Twenty-Four

Romans 6:15-23

Diagrams

Romans 6:15 Diagram

Romans 6:15 Τί οὖν; ἀμαρτήσομεν, (ἀμαρτήσωμεν) ὅτι οὐκ ἐσμὲν ὑπὸ νόμον, ἀλλ' (ἀλλά) ὑπὸ χάριν; μὴ γένοιτο.

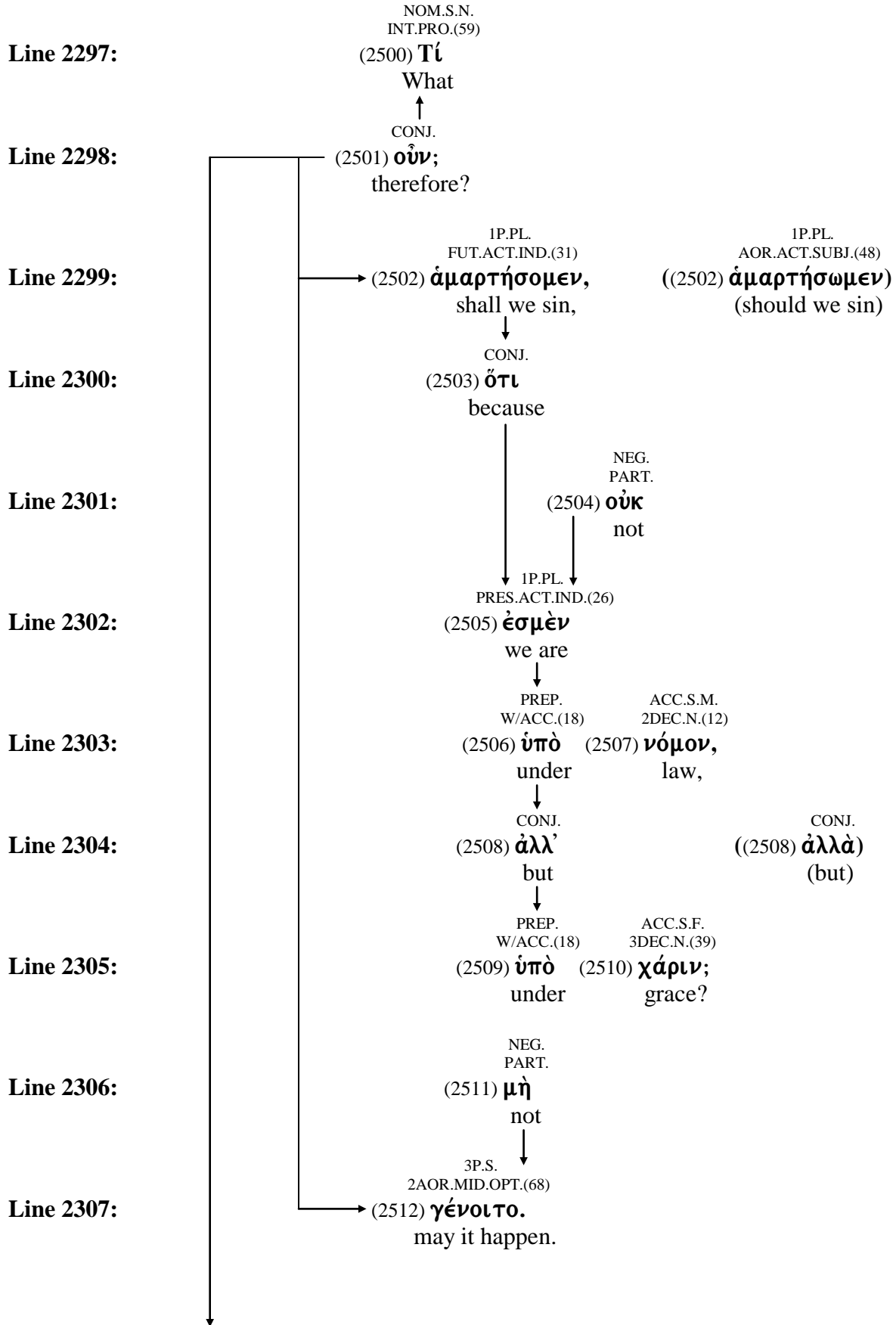

- (2500) **τίς** - interrogative pronoun = who, which, what
- (2501) **οὖν** - particle = therefore, then
- (2502) **ἁμαρτάνω** = sin, trespass
- (2503) **ὅτι** - conjunction = that, because
- (2504) **οὐ** - negative particle = no, not
- (2505) **εἰμί** = to be, exist
- (2506) **ὑπό** - preposition = by, under
- (2507) **νόμος** = a law, a command, anything established
- (2508) **ἀλλά** - conjunction = but
- (2509) **ὑπό** - preposition = by, under
- (2510) **χάρις** = grace
from **χαίρω** = rejoice
- (2511) **μή** - negative particle = no, not
- (2512) **γίνομαι** = to become

Romans 6:16 οὐκ οἶδατε ὅτι ᾧ παριστάνετε ἑαυτοὺς
 δούλους εἰς ὑπακοήν, δούλοι ἐστε ᾧ ὑπακούετε, ἦτοι
 ἁμαρτίας εἰς θάνατον, ἢ ὑπακοῆς εἰς δικαιοσύνην;

Romans 6:16 Diagram

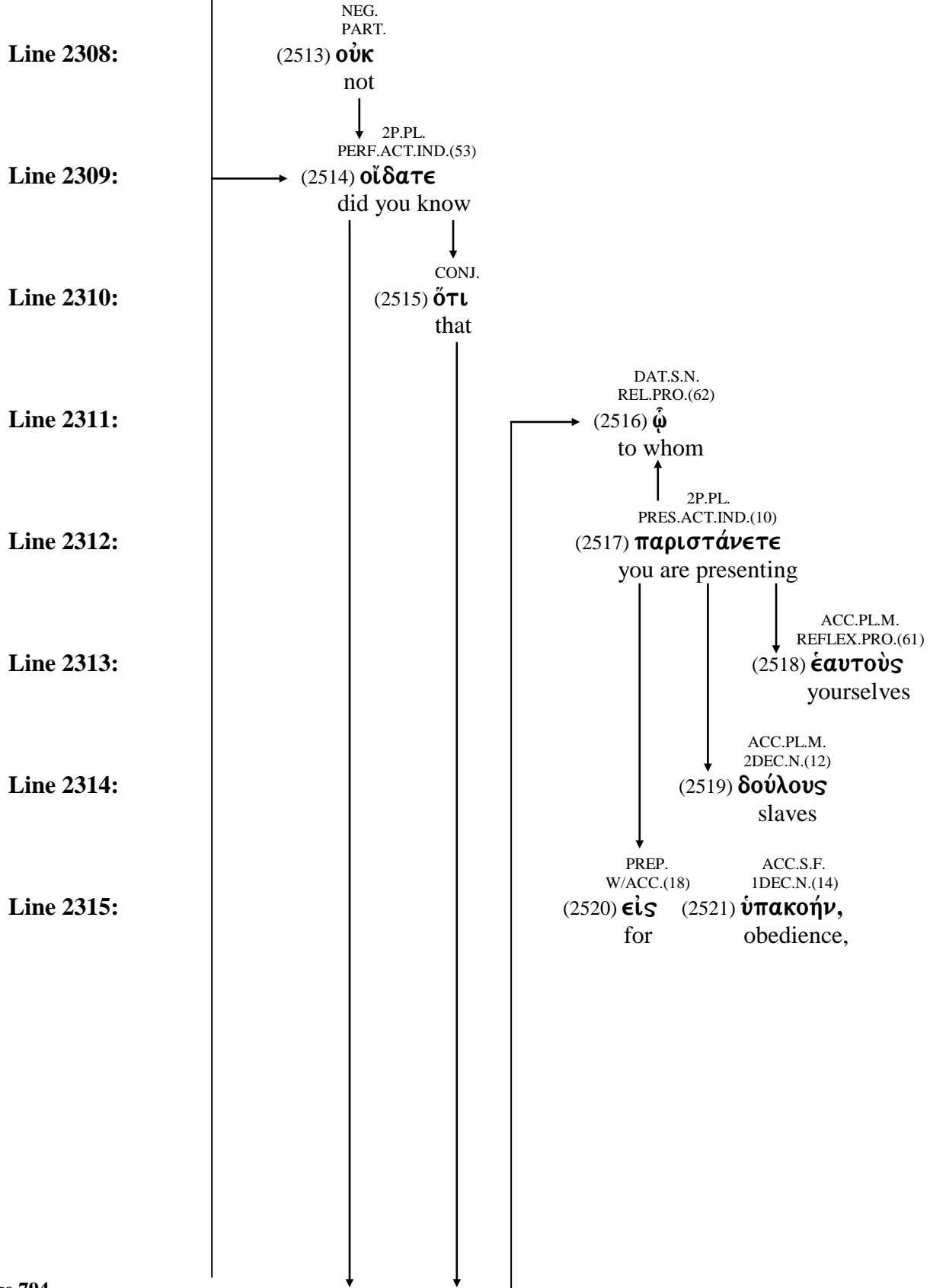

- (2513) **οὐ** - negative particle = no, not
- (2514) **οἶδα** = to see, to perceive with the eyes; to perceive with the senses
- (2515) **ὅτι** - conjunction = that, because
- (2516) **ὃς** - relative pronoun = who, which, what
- (2517) **παρίστημι** = to place alongside of, to present
from **παρά** - preposition = from, along side of, near
and **ἵστημι** = to place, set, to cause to stand
- (2518) **ἑαυτοῦ** - reflexive pronoun = himself
from **αὐτός** - third person personal pronoun = he, she, it
- (2519) **δούλος** - a slave
from **δέω** = to bind
- (2520) **εἰς** - preposition used with the accusative = to, unto, towards
- (2521) **ὑπακοή** = obedience; to put one's hearing under, obey
from **ὑπακούω** = to obey
from **ὑπό** – preposition = under, by
and **ἀκούω** = to hear

Romans 6:16 Diagram

Romans 6:16 οὐκ οἶδατε ὅτι ᾧ παριστάνετε ἑαυτοὺς
 δούλους εἰς ὑπακοήν, δούλοι ἐστε ᾧ ὑπακούετε, ἤτοι
 ἁμαρτίας εἰς θάνατον, ἢ ὑπακοῆς εἰς δικαιοσύνην;

Line 2316:

NOM.PL.M.
2DEC.N.(12)
(2522) δούλοι
slaves

Line 2317:

2P.PL.
PRES.ACT.IND.(26)
(2523) ἐστε
you are

Line 2318:

DAT.S.N.
REL.PRO.(62)
(2524) ᾧ
to whom

Line 2319:

2P.PL.
PRES.ACT.IND.(10)
(2525) ὑπακούετε,
you are obeying,

Line 2320:

PARTICLE
(2526) ἤτοι
whether

Line 2321:

GEN.S.F.
1DEC.N.(15)
(2527) ἁμαρτίας
of sin

Line 2322:

PREP.
W/ACC.(18) ACC.S.M.
2DEC.N.(12)
(2528) εἰς (2529) θάνατον,
for death,

Line 2323:

PARTICLE
(2530) ἢ
or

Line 2324:

GEN.S.F.
1DEC.N.(14)
(2531) ὑπακοῆς
of obedience

Line 2325:

PREP.
W/ACC.(18) ACC.S.F.
1DEC.N.(14)
(2532) εἰς (2533) δικαιοσύνην;
for righteousness?

- (2522) **δοῦλος** - a slave
from **δέω** = to bind
- (2523) **εἶμί** = to be, exist
- (2524) **ὅς** - relative pronoun = who, which, what
- (2525) **ὑπακούω** = to obey
from **ὑπό** – preposition = under, by
and **ἀκούω** = to hear
- (2526) **ἤτοι** - conjunction = whether, either
from **ἤ** - particle = either, or
and **τοι** - used as a particle of contrast
from **ὁ** - definite article = the
- (2527) **ἁμαρτία** = to miss the mark
from **ἁμαρτάνω** = sin, trespass
- (2528) **εἰς** - preposition used with the accusative = to, unto, towards
- (2529) **θάνατος** = death
from **θνήσκω** = to die
- (2530) **ἢ** - particle used as a conjunction = or
- (2531) **ὑπακοή** = obedience; to put one's hearing under, obey
from **ὑπακούω** = to obey
from **ὑπό** – preposition = under, by
and **ἀκούω** = to hear
- (2532) **εἰς** - preposition used with the accusative = to, unto, towards
- (2533) **δικαιοσύνη** = righteousness
from **δίκαιος** = righteous, just, right
from **δίκη** = judgment, execution of a sentence, punishment

Romans 6:17 Diagram

Romans 6:17 χάρις δὲ τῷ Θεῷ, ὅτι ἦτε δούλοι τῆς ἁμαρτίας, ὑπηκούσατε δὲ ἐκ καρδίας εἰς ὃν παρεδόθητε τύπον διδαχῆς·

Line 2326:

NOM.S.F.
3DEC.N.(39)
(2534) **χάρις**
thanks

Line 2327:

CONJ.
(2535) **δὲ**
now

Line 2328:

DAT.S.M.
2DEC.N.(12)
(2536) **τῷ**
the

Line 2329:

DAT.S.M.
2DEC.N.(12)
(2537) **Θεῷ,**
to God,

Line 2330:

CONJ.
(2538) **ὅτι**
because

Line 2331:

2P.PL.
IMPERF.ACT.IND.(26)
(2539) **ἦτε**
you were

Line 2332:

NOM.PL.M.
2DEC.N.(12)
(2540) **δούλοι**
slaves

Line 2333:

GEN.S.F.
ART.(13)
(2541) **τῆς**
the

Line 2334:

GEN.S.F.
1DEC.N.(15)
(2542) **ἁμαρτίας,**
of sin,

- (2534) **χάρις** = grace
from **χαίρω** = rejoice
- (2535) **δέ** - conjunction = and, now, even
- (2536) **ὁ** - article = the
- (2537) **θεός** = God, deity
- (2538) **ὅτι** - conjunction = that, because
- (2539) **εἰμί** = to be, exist
- (2540) **δοῦλος** - a slave
from **δέω** = to bind
- (2541) **ὁ** - article = the
- (2542) **ἁμαρτία** = to miss the mark
from **ἁμαρτάνω** = sin, trespass

Romans 6:17 Diagram

Romans 6:17 χάρις δὲ τῷ Θεῷ, ὅτι ἦτε δούλοι τῆς ἁμαρτίας, ὑπηκούσατε δὲ ἐκ καρδίας εἰς ὃν παρεδόθητε τύπον διδαχῆς·

Line 2335:

2P.PL.
AOR.ACT.IND.(33)
(2543) ὑπηκούσατε
you obeyed

Line 2336:

CONJ.
(2544) δὲ
and

Line 2337:

PREP. GEN.S.F.
W/GEN.(18) 1DEC.N.(15)
(2545) ἐκ (2546) καρδίας
out of heart

Line 2338:

PREP. ACC.S.M.
W/ACC.(18) REL.PRO.(62)
(2547) εἰς (2548) ὃν
into which

Line 2339:

2P.PL.
AOR.PASS.IND.(37)
(2549) παρεδόθητε
you were delivered

Line 2340:

ACC.S.M.
2DEC.N.(12)
(2550) τύπον
type

Line 2341:

GEN.S.F.
1DEC.N.(14)
(2551) διδαχῆς·
of doctrine;

- (2543) **ὑπακούω** = to obey
from **ὑπό** – preposition = under, by
and **ἀκούω** = to hear
- (2544) **δέ** - conjunction = and, now, even
- (2545) **ἐκ** - preposition used with the genitive = out of, from
- (2546) **καρδία** = heart
- (2547) **εἰς** - preposition used with the accusative = to, unto, towards
- (2548) **ὅς** - relative pronoun = who, which, what
- (2549) **παραδίδωμι** = to give over
from **παρά** - preposition = from, along side of, near
and **δίδωμι** = to give
- (2550) **τύπος** = mark, pattern, image
from **τύπτω** = to strike, to beat
- (2551) **διδαχή** = an act of teaching, instruction, doctrine
from **διδάσκω** = to teach

Romans 6:18 Diagram

Romans 6:18 ἐλευθερωθέντες δὲ ἀπὸ τῆς ἁμαρτίας, ἐδουλώθητε τῇ δικαιοσύνῃ.

Line 2342:

NOM.PL.M.
AOR.PASS.PART.(45)
(2552) ἐλευθερωθέντες
having become free

Line 2343:

CONJ.
(2553) δὲ
and

Line 2344:

PREP.
W/GEN.(18)
(2554) ἀπὸ
from

Line 2345:

GEN.S.F.
ART.(13)
(2555) τῆς
the

Line 2346:

GEN.S.F.
1DEC.N.(15)
(2556) ἁμαρτίας,
sin,

Line 2347:

2P.PL.
AOR.PASS.IND.(37)
(2557) ἐδουλώθητε
you were enslaved

Line 2348:

DAT.S.F.
ART.(13)
(2558) τῇ
the

Line 2349:

DAT.S.F.
1DEC.N.(14)
(2559) δικαιοσύνῃ.
to righteousness.

- (2552) **ἐλευθερώω** = to set free, to deliver
from **ἐλεύθερος** - adjective = freedom, liberty
from **ἔρχομαι** = to come, to go
- (2553) **δὲ** - conjunction = and, now, even
- (2554) **ἀπό** - preposition used with the genitive = from, out of
- (2555) **ὁ** - article = the
- (2556) **ἁμαρτία** = to miss the mark
from **ἁμαρτάνω** = sin, trespass
- (2557) **δουλόω** = to enslave, to bring into bondage
from **δοῦλος** = a slave
from **δέω** = to bind
- (2558) **ὁ** - article = the
- (2559) **δικαιοσύνη** = righteousness
from **δίκαιος** = righteous, just, right
from **δίκη** = judgment, execution of a sentence, punishment

Romans 6:19 ἀνθρώπινον λέγω διὰ τὴν ἀσθένειαν τῆς σαρκὸς ὑμῶν ὥσπερ γὰρ παρεστήσατε τὰ μέλη ὑμῶν δούλα τῇ ἀκαθαρσίᾳ καὶ τῇ ἀνομίᾳ εἰς τὴν ἀνομίαν, οὕτω(ς) νῦν παραστήσατε τὰ μέλη ὑμῶν δούλα τῇ δικαιοσύνῃ εἰς ἁγιασμόν.

Romans 6:19 Diagram

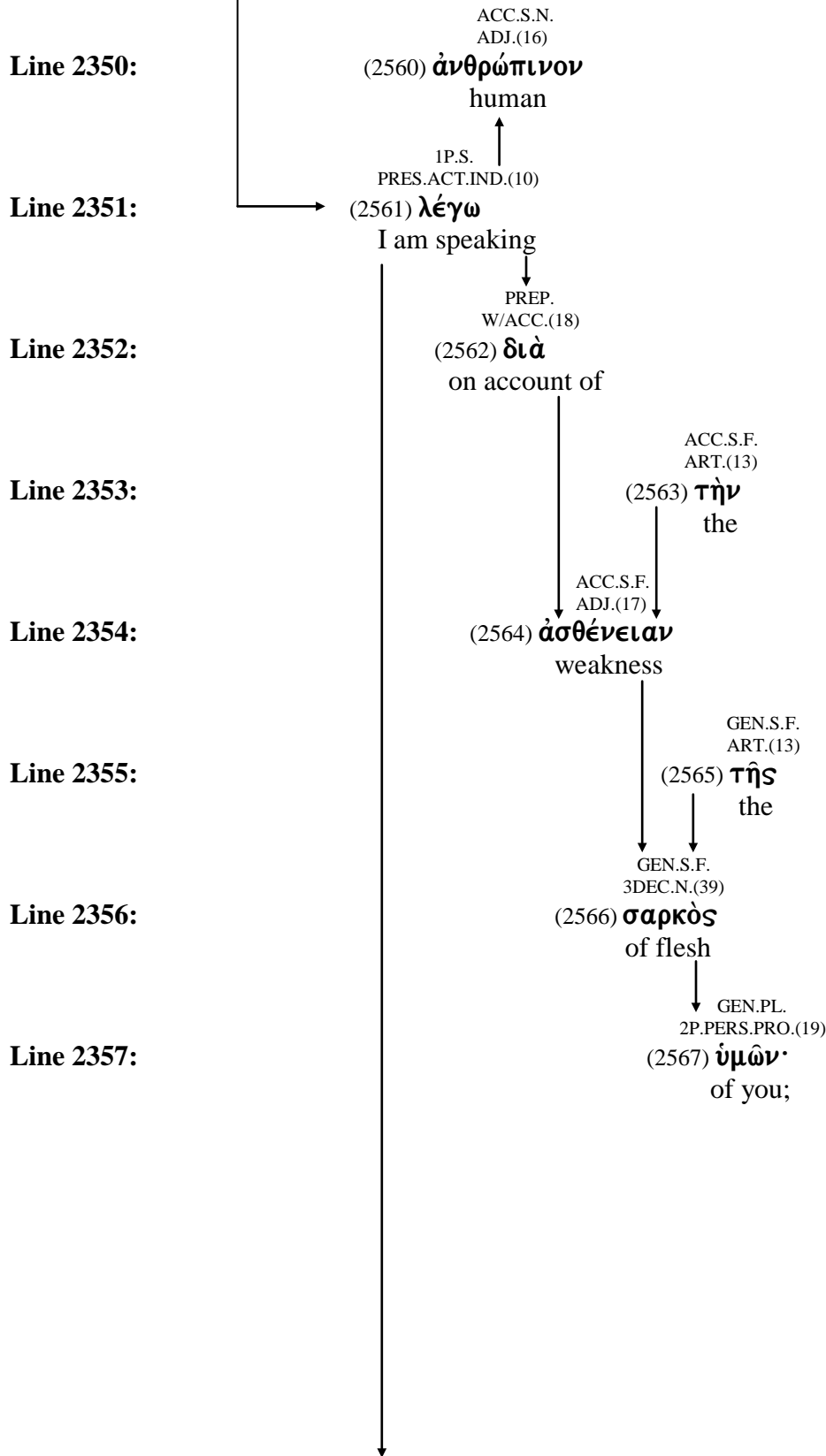

- (2560) **ἀνθρώπινος** - adjective = human, belonging to man
from **ἄνθρωπος** = a man, a human being
from **ἄνήρ** = a male
and **ὄψ** = the face or countenance
- (2561) **λέγω** = to say, to speak
- (2562) **διά** - preposition used with the accusative = on account of
- (2563) **ὁ** - article = the
- (2564) **ἀσθένεια** = weakness, lack of strength
from **ἀσθενής** - adjective = feeble, weak, sick
from **α** - used as a negative particle
and **σθενώ** = to strengthen
from **ἵστημι** = to stand
- (2565) **ὁ** - article = the
- (2566) **σάρξ** = flesh
- (2567) **σύ** - second person personal pronoun = you

Romans 6:19 Diagram

Romans 6:19 ἀνθρώπινον λέγω διὰ τὴν ἀσθένειαν τῆς σαρκὸς ὑμῶν ὥσπερ γὰρ παρεστήσατε τὰ μέλη ὑμῶν δούλα τῇ ἀκαθαρσίᾳ καὶ τῇ ἀνομίᾳ εἰς τὴν ἀνομίαν, οὕτω(ς) νῦν παραστήσατε τὰ μέλη ὑμῶν δούλα τῇ δικαιοσύνῃ εἰς ἁγιασμόν.

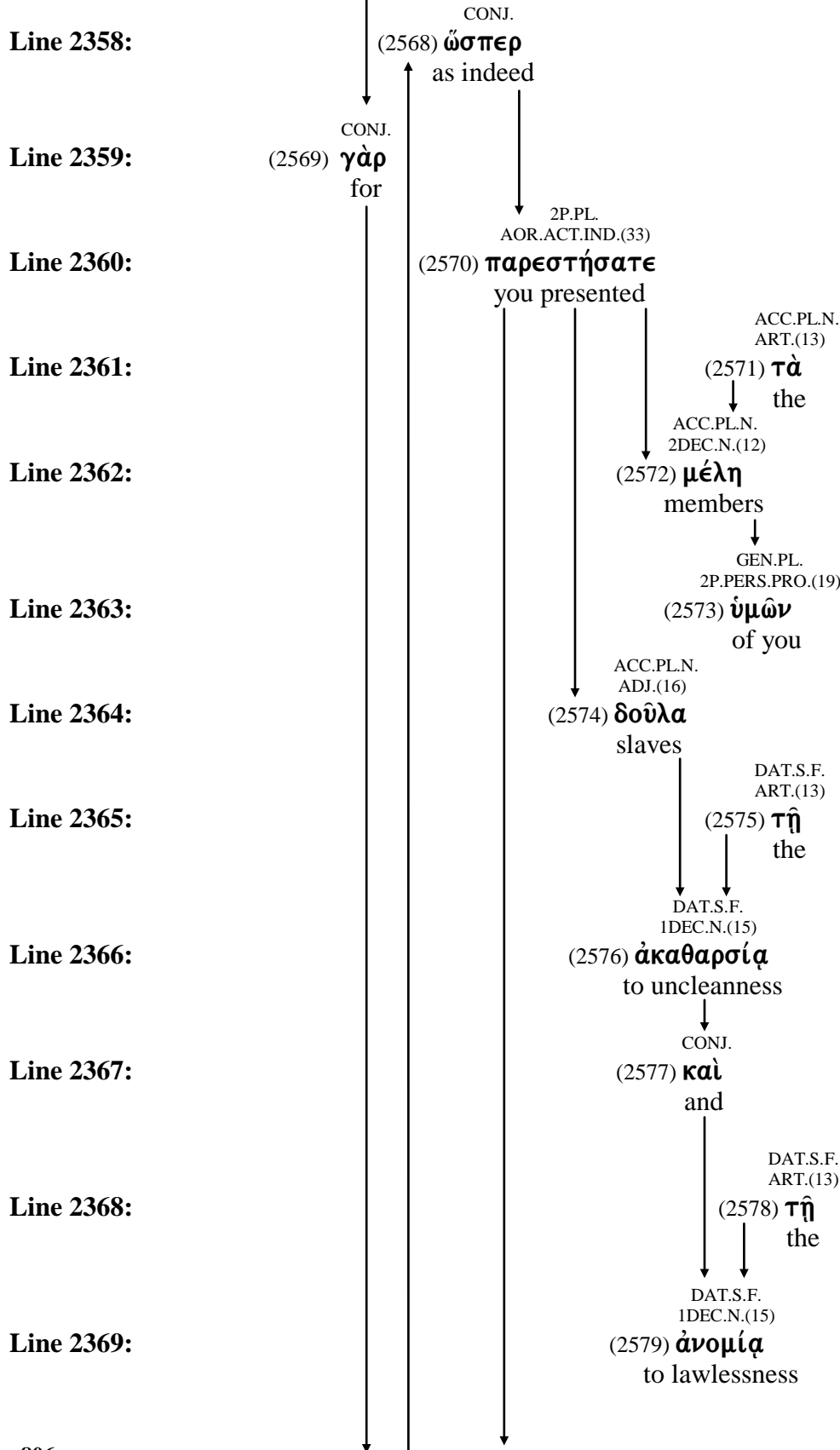

- (2568) **ὥσπερ** - conjunction = as indeed
from **ὥς** - conjunction = as, like
from **ὃς** - relative pronoun = who, which, what
and **περ** - particle of emphasis = indeed
from **πέραν** - adverb = beyond
- (2569) **γάρ** - conjunction = for
- (2570) **παρίστημι** = to place alongside of, to present
from **παρά** - preposition = from, along side of, near
and **ἵστημι** = to place, set, to cause to stand
- (2571) **ὁ** - article = the
- (2572) **μέλος** = a member, limb, any part of the body
- (2573) **σύ** - second person personal pronoun = you
- (2574) **δούλος** = a slave
from **δέω** = to bind
- (2575) **ὁ** - article = the
- (2576) **ἀκαθαρσία** = uncleanness, either physical or moral; ceremonial impurity
from **ἀκάθαρτος** - adjective = unclean
- (2577) **καί** - conjunction = and, also, even
- (2578) **ὁ** - article = the
- (2579) **ἀνομία** = without law, lawlessness
from **ἄνομος** - adjective = lawless
from **α** - used as a negative particle
and **νόμος** = law

Romans 6:19 Diagram

Romans 6:19 ἀνθρώπινον λέγω διὰ τὴν ἀσθένειαν τῆς σαρκὸς ὑμῶν· ὥσπερ γὰρ παρεστήσατε τὰ μέλη ὑμῶν δούλα τῇ ἀκαθαρσίᾳ καὶ τῇ ἀνομίᾳ εἰς τὴν ἀνομίαν, οὕτω(ς) νῦν παραστήσατε τὰ μέλη ὑμῶν δούλα τῇ δικαιοσύνῃ εἰς ἁγιασμόν.

Line 2370:

Line 2371:

Line 2372:

Line 2373:

Line 2374:

Line 2375:

Line 2376:

Line 2377:

Line 2378:

Line 2379:

Line 2380:

Line 2381:

Line 2382:

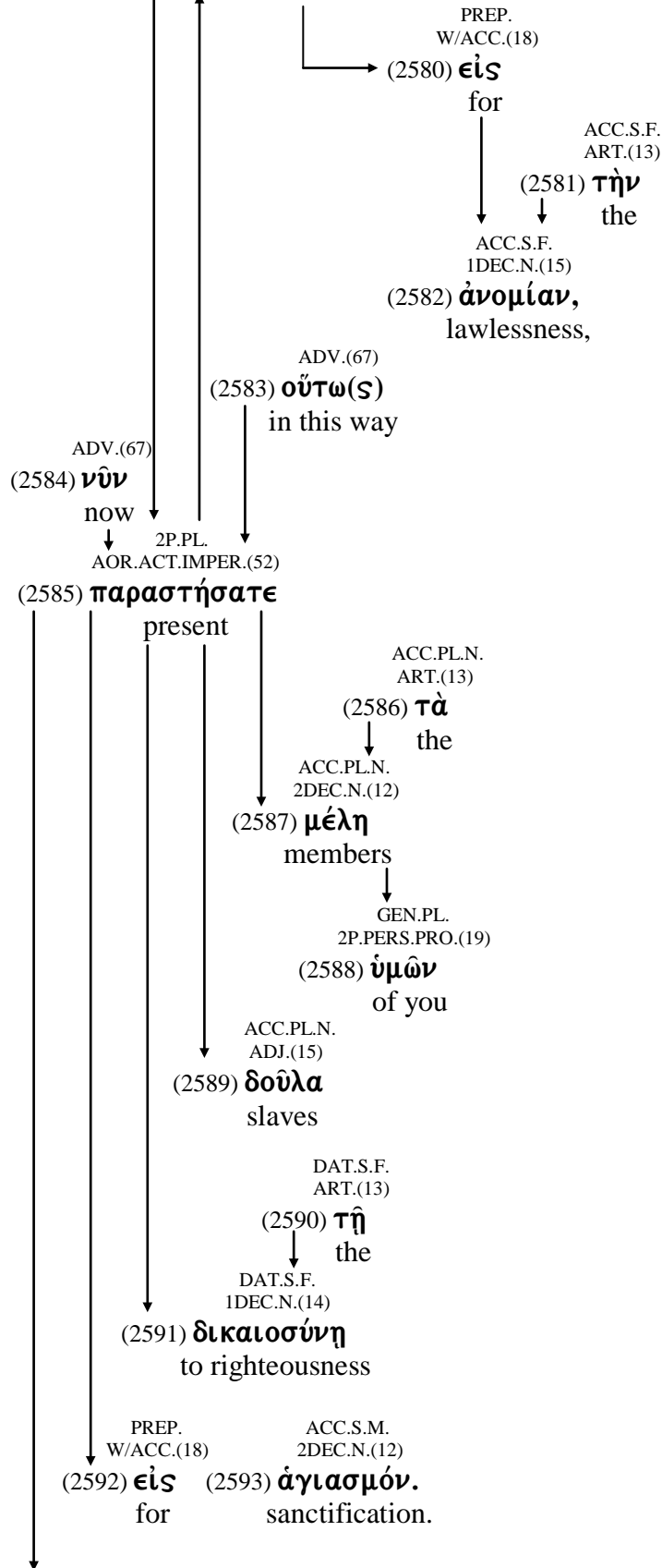

(2580) **εἰς** - preposition used with the accusative = to, unto, towards

(2581) **ὁ** - article = the

(2582) **ἀνομία** = without law, lawlessness
from **ἄνομος** - adjective = lawless
from **α** - used as a negative particle
and **νόμος** = law

(2583) **οὕτως** - adverb = so, thus, in this manner
from **οὗτος** - demonstrative pronoun = this

(2584) **νῦν** - adverb = now, the present

(2585) **παρίστημι** = to place alongside of, to present
from **παρά** - preposition = from, along side of, near
and **ἵστημι** = to place, set, to cause to stand

(2586) **ὁ** - article = the

(2587) **μέλος** = a member, limb, any part of the body

(2588) **σύ** - second person personal pronoun = you

(2589) **δούλος** = a slave
from **δέω** = to bind

(2590) **ὁ** - article = the

(2591) **δικαιοσύνη** = righteousness
from **δίκαιος** = righteous, just, right
from **δίκη** = judgment, execution of a sentence, punishment

(2592) **εἰς** - preposition used with the accusative = to, unto, towards

(2593) **ἀγιασμός** = sanctification, holiness
from **ἀγιάζω** = to sanctify, to make holy
from **ἅγιος** - adjective = holy, saint, separated one

Romans 6:20 ὅτε γὰρ δοῦλοι ἦτε τῆς ἀμαρτίας, ἐλεύθεροι ἦτε τῇ δικαιοσύνῃ.

Romans 6:20 Diagram

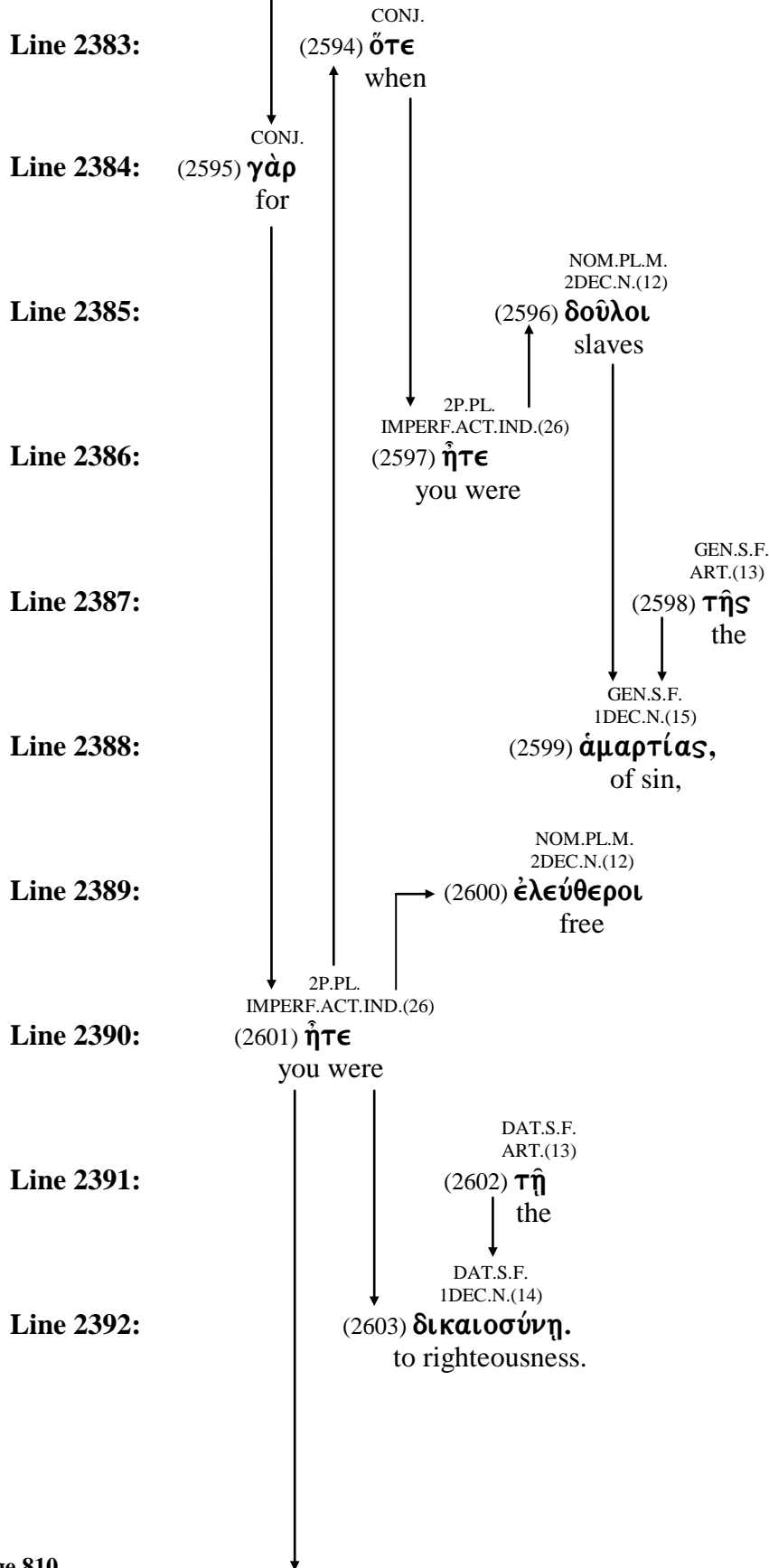

- (2594) **ὅτε** - conjunction = when
from **ὅς** - relative pronoun = who, which, what
- (2595) **γάρ** - conjunction = for
- (2596) **δοῦλος** = a slave
from **δέω** = to bind
- (2597) **εἰμί** = to be, exist
- (2598) **ὁ** - article = the
- (2599) **ἀμαρτία** = to miss the mark
from **ἀμαρτάνω** = sin, trespass
- (2600) **ἐλεύθερος** - adjective = freedom, liberty
from **ἔρχομαι** = to come, to go
- (2601) **εἰμί** = to be, exist
- (2602) **ὁ** - article = the
- (2603) **δικαιοσύνη** = righteousness
from **δίκαιος** = righteous, just, right
from **δίκη** = judgment, execution of a sentence, punishment

Romans 6:21 τίνα οὖν καρπὸν εἶχετε τότε ἐφ' οἷς νῦν ἐπαισχύνεσθὲ τὸ γὰρ τέλος ἐκείνων θάνατος.

Romans 6:21 Diagram

Line 2393:

ACC.S.M.
INTER.PRO.(59)
(2604) **τίνα**
what

Line 2394:

CONJ.
(2605) **οὖν**
therefore

Line 2395:

ACC.S.M.
2DEC.N.(12)
(2606) **καρπὸν**
fruit

Line 2396:

2P.PL. ↑
IMPERF.ACT.IND.(25)
(2607) **εἶχετε**
you were having

Line 2397:

ADV.(67)
(2608) **τότε**
then

Line 2398:

PREP.
W/DAT.(18) (2609) **ἐφ'** upon
DAT.PL.N.
REL.PRO.(62) (2610) **οἷς** which

Line 2399:

ADV.(67)
(2611) **νῦν**
now

Line 2400:

2P.PL. ↓
PRES.MID.IND.(23)
(2612) **ἐπαισχύνεσθε;**
you are ashamed?

Line 2401:

NOM.S.N.
ART.(13)
(2613) **τὸ**
the

Line 2402:

CONJ.
(2614) **γὰρ**
for

Line 2403:

NOM.S.N.
2DEC.N.(12)
(2615) **τέλος**
end

Line 2404:

GEN.PL.N.
DEM.PRO.(22)
(2616) **ἐκείνων**
of those things

Line 2405:

NOM.S.M.
2DEC.N.(12)
(2617) **θάνατος.**
death.

- (2604) **τίς** - interrogative pronoun = who, which, what
- (2605) **οὖν** - particle = therefore, then
- (2606) **καρπός** = fruit
- (2607) **ἔχω** = to have, to hold
- (2608) **τότε** - adverb = then
from **ὁ** - definite article = then
and **ὅτε** - particle = when
- (2609) **ἐπί** - preposition used with the dative = on the basis of
- (2610) **ὅς** - relative pronoun = who, which, what
- (2611) **νῦν** - adverb = now, the present
- (2612) **ἐπαισχύνομαι** = to be ashamed, to feel shame
from **ἐπί** - preposition = upon
and **αἰσχύνομαι** = ashamed
- (2613) **ὁ** - article = the
- (2614) **γάρ** - conjunction = for
- (2615) **τέλος** = the end, finished
- (2616) **ἐκεῖνος** - demonstrative pronoun = that, those
from **ἐκεῖ** - adverb = there
- (2617) **θάνατος** = death
from **θνήσκω** = to die

Romans 6:22 νυνὶ δὲ ἐλευθερωθέντες ἀπὸ τῆς ἁμαρτίας, δουλωθέντες δὲ τῷ Θεῷ, ἔχετε τὸν καρπὸν ὑμῶν εἰς ἁγιασμόν, τὸ δὲ τέλος ζωῆν αἰώνιον.

Romans 6:22 Diagram

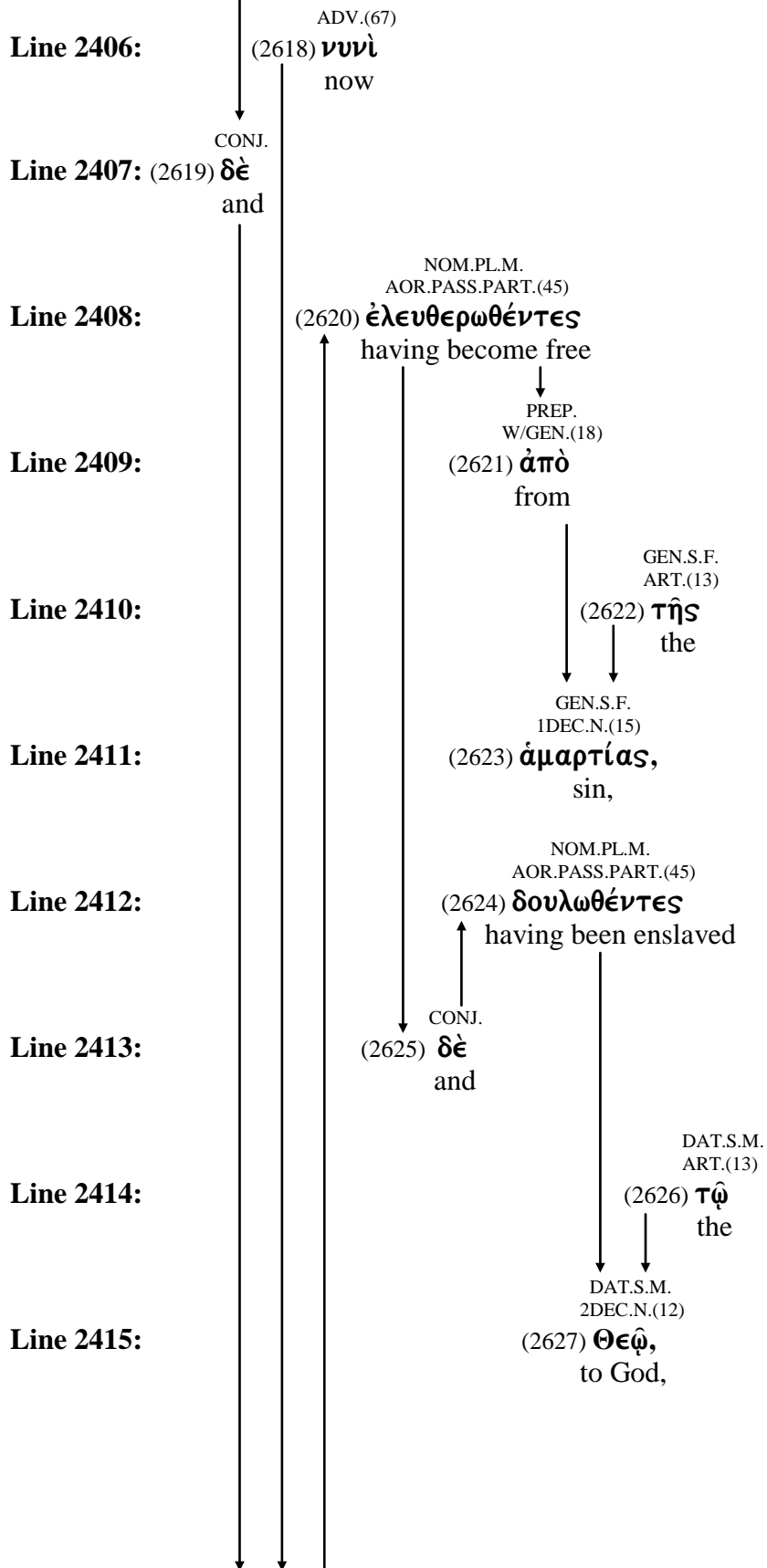

(2618) **νυνί** - adverb, a prolonged form of **νῦν** for emphasis = now, at this present time

(2619) **δὲ** - conjunction = and, now, even

(2620) **ἐλευθερώω** = to set free, to deliver
from **ἐλεύθερος** - adjective = freedom, liberty
from **ἔρχομαι** = to come, to go

(2621) **ἀπό** - preposition used with the genitive = from, out of

(2622) **ὁ** - article = the

(2623) **ἁμαρτία** = to miss the mark
from **ἁμαρτάνω** = sin, trespass

(2624) **δουλώω** = to enslave, to bring into bondage
from **δούλος** = slave, bondman
from **δέω** = to bind

(2625) **δὲ** - conjunction = and, now, even

(2626) **ὁ** - article = the

(2627) **θεός** = God, deity

Romans 6:22 νυνὶ δὲ ἐλευθερωθέντες ἀπὸ τῆς ἁμαρτίας,
 δουλωθέντες δὲ τῷ Θεῷ, ἔχετε τὸν καρπὸν ὑμῶν εἰς
 ἁγιασμόν, τὸ δὲ τέλος ζωῆν αἰώνιον.

Romans 6:22 Diagram

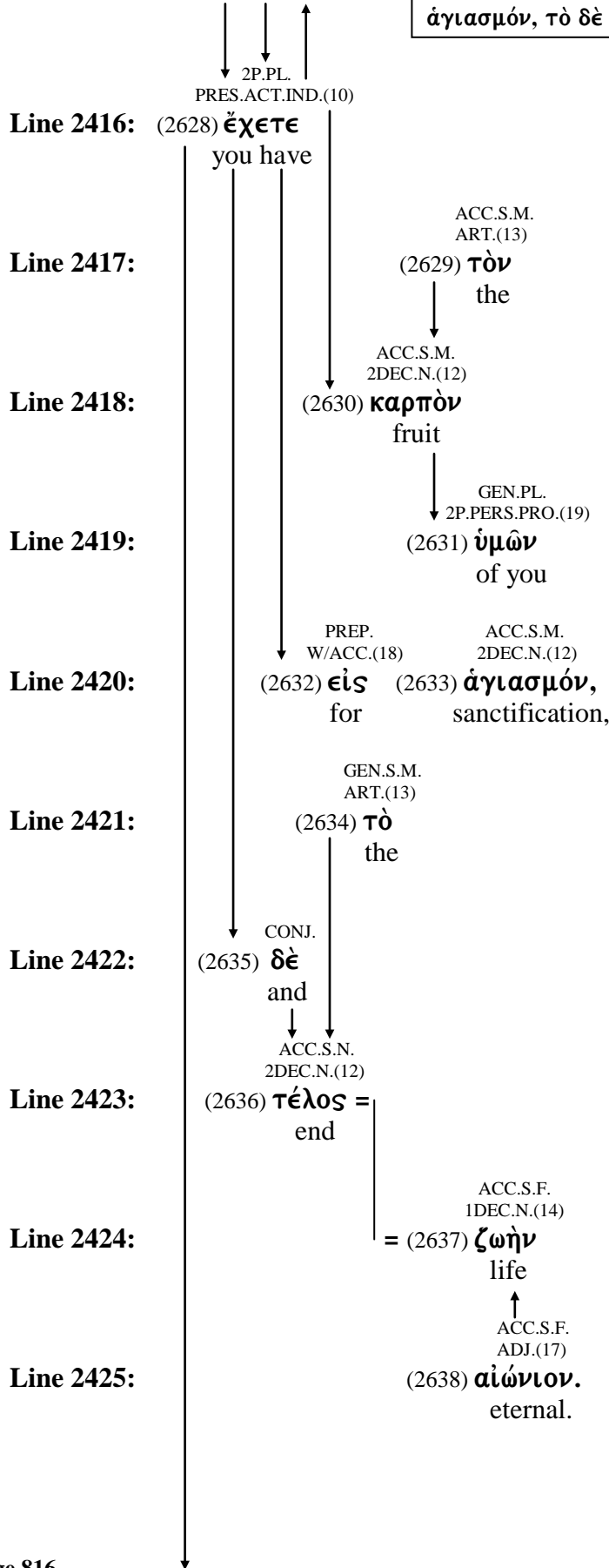

(2628) ἔχω = to have, to hold

(2629) ὁ - article = the

(2630) καρπός = fruit

(2631) σύ - second person personal pronoun = you

(2632) εἰς - preposition used with the accusative = to, unto, towards

(2633) ἁγιασμός = sanctification, holiness

from ἁγιάζω = to sanctify, to make holy

from ἅγιος - adjective = holy, saint, separated one

(2634) ὁ - article = the

(2635) δὲ - conjunction = and, now, even

(2636) τέλος = the end, finished

from τέλλω = to aim for a point or goal

(2637) ζωή = life

from ζάω = to live, to breathe

(2638) αἰώνιος - adjective = unlimited duration, eternal, forever

from αἰών = ever, eternal

Romans 6:23 τὰ γὰρ ὀψώνια τῆς ἀμαρτίας θάνατος, τὸ δὲ χάρισμα τοῦ Θεοῦ ζωὴ αἰώνιος ἐν Χριστῷ Ἰησοῦ τῷ Κυρίῳ ἡμῶν.

Romans 6:23 Diagram

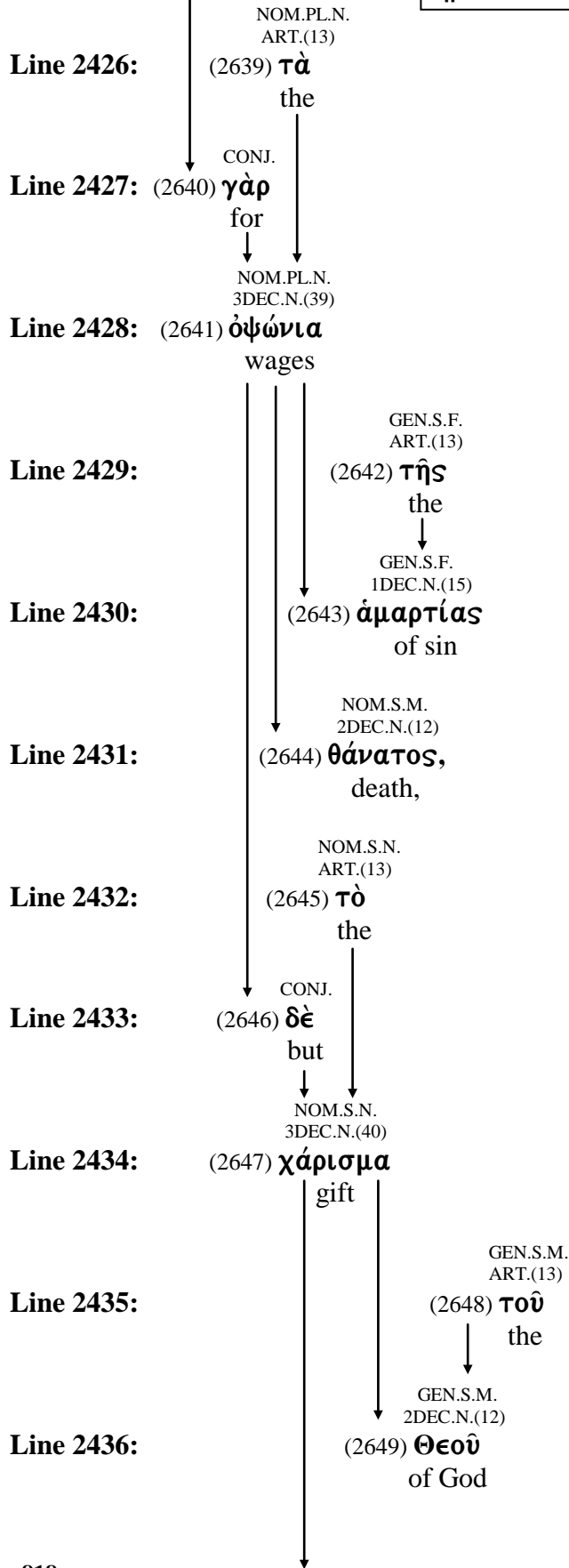

(2639) **ὁ** - article = the

(2640) **γάρ** - conjunction = for

(2641) **ὁψώνιον** - article = the

(2642) **ὁ** - article = the

(2643) **ἁμαρτία** = to miss the mark
from **ἁμαρτάνω** = sin, trespass

(2644) **θάνατος** = death
from **θνήσκω** = to die

(2645) **ὁ** - article = the

(2646) **δὲ** - conjunction = and, now, even

(2647) **χάρισμα** = a gift, an expression of grace or favor
from **χαρίζομαι** = to give, to bestow, to deliver
from **χάρις** = grace
from **χαίρω** = to rejoice

(2648) **ὁ** - article = the

(2649) **θεός** = God, deity

Romans 6:23 τὰ γὰρ ὀψώνια τῆς ἀμαρτίας θάνατος, τὸ δὲ χάρισμα τοῦ Θεοῦ ζωὴ αἰώνιος ἐν Χριστῷ Ἰησοῦ τῷ Κυρίῳ ἡμῶν.

Romans 6:23 Diagram

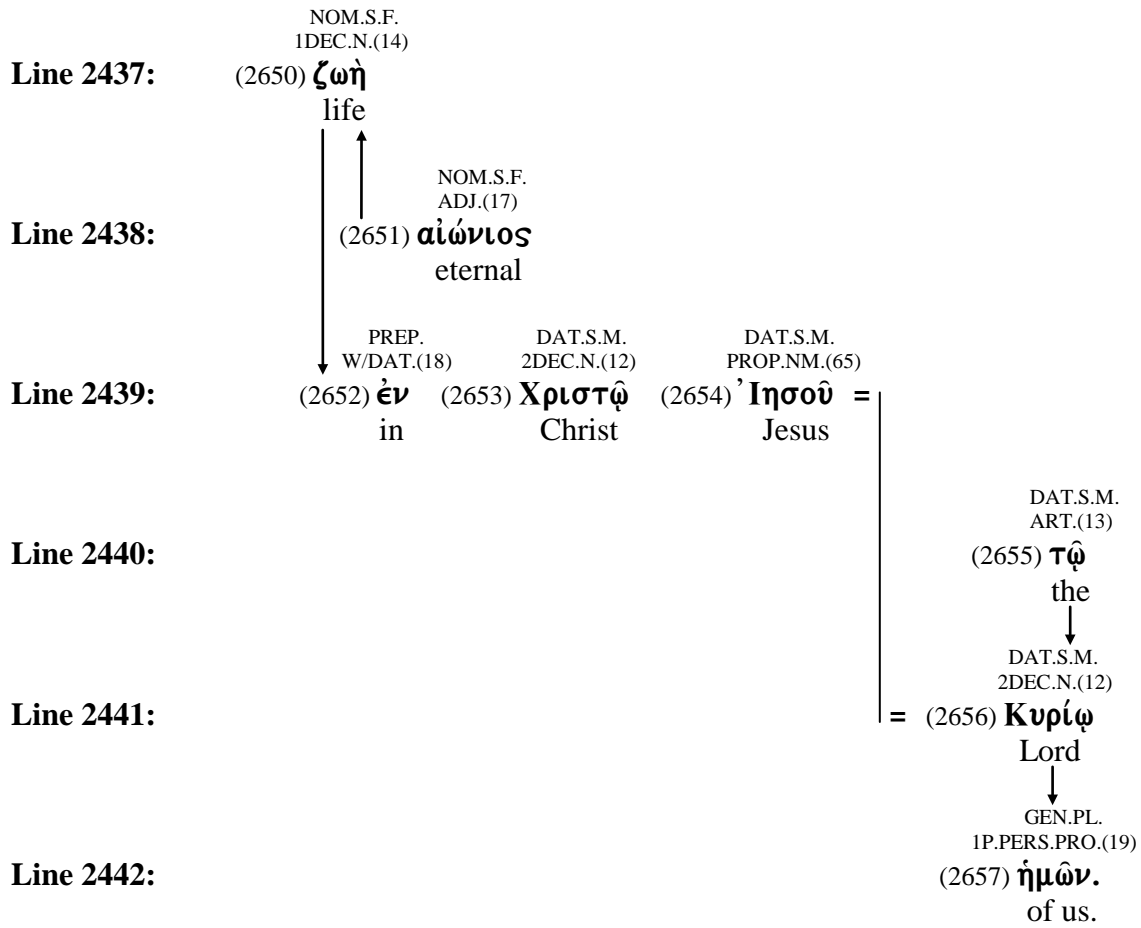

- (2650) **ζωή** = life
from **ζάω** = to live, to breathe
- (2651) **αἰώνιος** - adjective = unlimited duration, eternal, forever
from **αἰών** = ever, eternal
- (2652) **ἐν** - preposition used with the dative = in
- (2653) **Χριστός** = Christ
meaning “anointed” - from **χρίω** = to anoint
- (2654) **Ἰησοῦς** = Jesus
of Hebrew origin - from **יְהוֹשֻׁעַ** = Joshua or Jehoshua = “Yahweh is salvation”
from **יְהוָה** = Yahweh = “the existing One”
from **הָיָה** = to be, become, come to
and **שָׁמַר** = to save, be saved, be delivered, to rescue
- (2655) **ὁ** - article = the
- (2656) **κύριος** = lord, master
from **κύρος** = supremacy
- (2657) **ἐγώ** - first person personal pronoun = I

