

Lesson Twenty-Three

Romans 6:8-14

- 8) εἰ δὲ ἀπεθάνομεν σὺν Χριστῷ, πιστεύομεν ὅτι καὶ συζήσομεν
if and we died with Christ, we believe that also we will live with

αὐτῷ·
Him;

- 9) εἰδότες ὅτι Χριστὸς ἐγερθεὶς ἐκ νεκρῶν οὐκέτι
knowing that Christ having been raised out of dead no longer

ἀποθνήσκει· θάνατος αὐτοῦ οὐκέτι κυριεύει.
He is dying; death Him no longer is lording over.

- 10) ὃ γὰρ ἀπέθανε(ν), τῇ ἁμαρτίᾳ ἀπέθανεν ἐφάπαξ· ὃ δὲ
what for He died, the to sin He died once; what and

ζῆ, ζῆ τῷ Θεῷ.
He is living, He is living the to God.

- 11) οὕτω(ς) καὶ ὑμεῖς λογίζεσθε ἑαυτοὺς (εἶναι) νεκροὺς μὲν
in this way also yourselves you be imputing yourselves (to be) dead indeed

εἶναι τῇ ἁμαρτίᾳ, ζῶντας δὲ τῷ Θεῷ ἐν Χριστῷ Ἰησοῦ [τῷ
to be the to sin, living and the to God in Christ Jesus [the

Κυρίῳ ἡμῶν].
Lord of us].

12) Μὴ οὖν βασιλεύτω ἡ ἁμαρτία ἐν τῷ θνητῷ ὑμῶν σώματι,
Not therefore let reign the sin in the mortal of you body,

εἰς τὸ ὑπακούειν [αὐτῇ ἐν] ταῖς ἐπιθυμίαις αὐτοῦ·
for the to obey [it in] the lusts of it;

13) μηδὲ παριστάνετε τὰ μέλη ὑμῶν ὄπλα ἀδικίας τῇ
neither be presenting the members of you instruments of unrighteousness the

ἁμαρτία· ἀλλὰ παραστήσατε ἑαυτοὺς τῷ Θεῷ ὡσεὶ ἐκ νεκρῶν
to sin; but present yourselves the to God as if out of dead

ζῶντας, καὶ τὰ μέλη ὑμῶν ὄπλα δικαιοσύνης τῷ Θεῷ.
living, and the members of you instruments of righteousness the to God.

14) ἁμαρτία γὰρ ὑμῶν οὐ κυριεύσει· οὐ γὰρ ἐστε ὑπὸ νόμον,
sin for you not will lord over; not for you are under law,

ἀλλὰ ὑπὸ χάριν.
but under grace.

Word Association Diagram

Romans 6:8-14

VERSE 8

Line 2191:

Line 2192:

Line 2193:

Line 2194:

Line 2195:

Line 2196:

Line 2197:

Line 2198:

Line 2199:

VERSE 9

Line 2200:

Line 2201:

Line 2202:

Line 2203:

Line 2204:

Line 2205:

Line 2206:

Line 2207:

Line 2208:

Line 2209:

Line 2210:

VERSE 10

Line 2211:

Line 2212:

Line 2213:

Line 2214:

Line 2215:

Line 2216:

Line 2217:

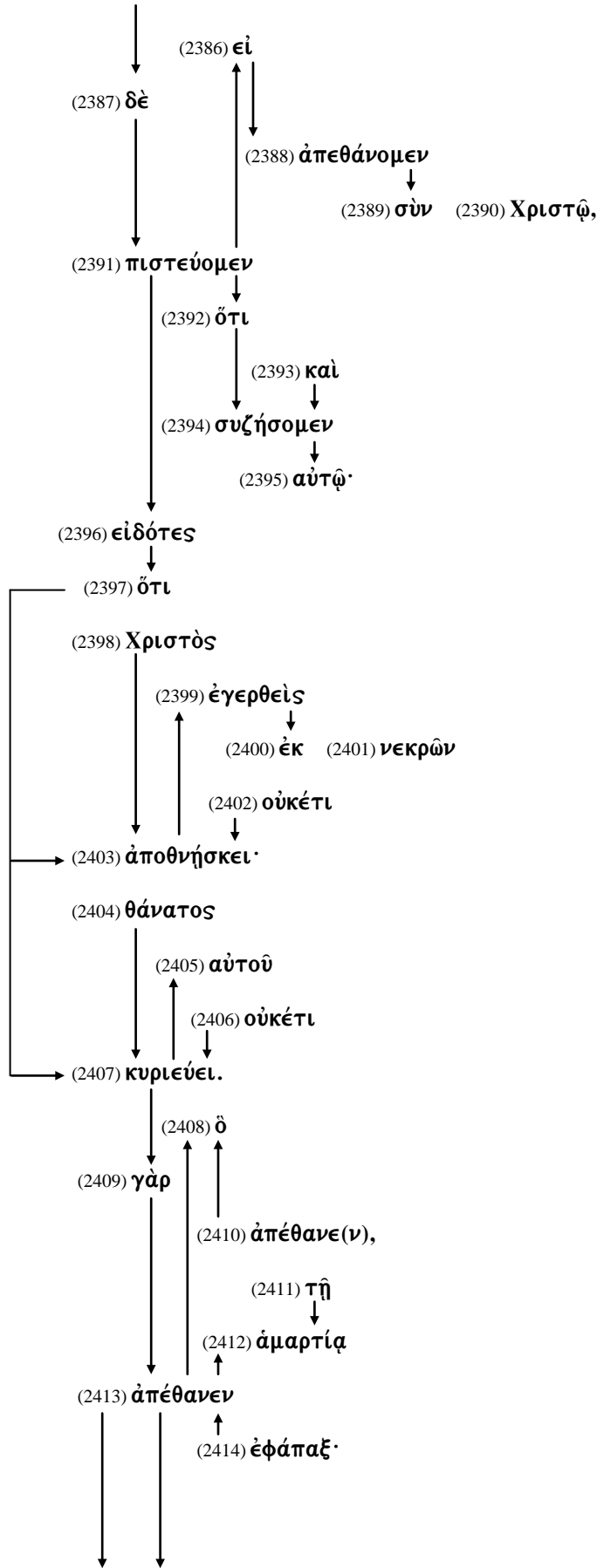

VERSE 10 (continued)

Line 2218:

Line 2219:

Line 2220:

Line 2221:

Line 2222:

Line 2223:

VERSE 11

Line 2224:

Line 2225:

Line 2226:

Line 2227:

Line 2228:

Line 2229:

Line 2230:

Line 2231:

Line 2232:

Line 2233:

Line 2234:

Line 2235:

Line 2236:

Line 2237:

Line 2238:

Line 2239:

Line 2240:

Line 2241:

Line 2242:

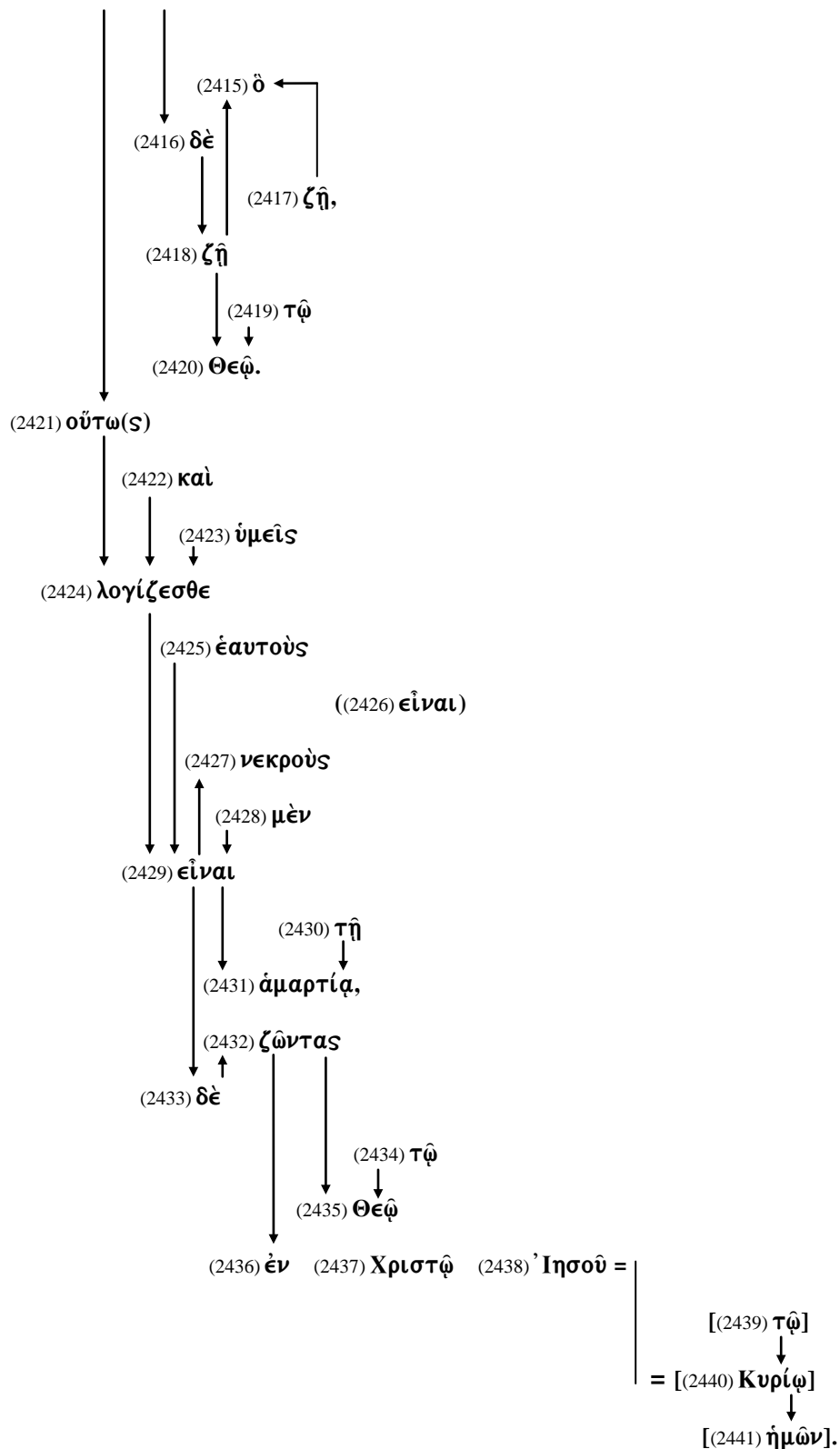

Word Association Diagram

Romans 6:8-14

VERSE 12

Line 2243:

(2442) Μή

Line 2244:

(2443) οὖν

Line 2245:

(2444) βασιλευέτω

Line 2246:

(2445) ἥ

Line 2247:

(2446) ἀμαρτία

Line 2248:

(2447) ἐν

Line 2249:

(2448) τῷ

Line 2250:

(2449) θνητῷ

Line 2251:

(2450) ὑμῶν

Line 2252:

(2451) σώματι,

Line 2253:

(2452) εἰς

Line 2254:

(2453) τὸ

Line 2255:

(2454) ὑπακούειν

Line 2256:

[(2455) αὐτῇ]

Line 2257:

[(2456) ἐν]

Line 2258:

(2457) ταῖς

Line 2259:

(2458) ἐπιθυμίαις

Line 2260:

(2459) αὐτοῦ·

VERSE 13

Line 2261:

(2460) μηδὲ

Line 2262:

(2461) παριστάνετε

Line 2263:

(2462) τὰ

Line 2264:

(2463) μέλη

Line 2265:

(2464) ὑμῶν

Line 2266:

(2465) ὅπλα

Line 2267:

(2466) ἀδικίας

Line 2268:

(2467) τῇ

Line 2269:

(2468) ἀμαρτία·

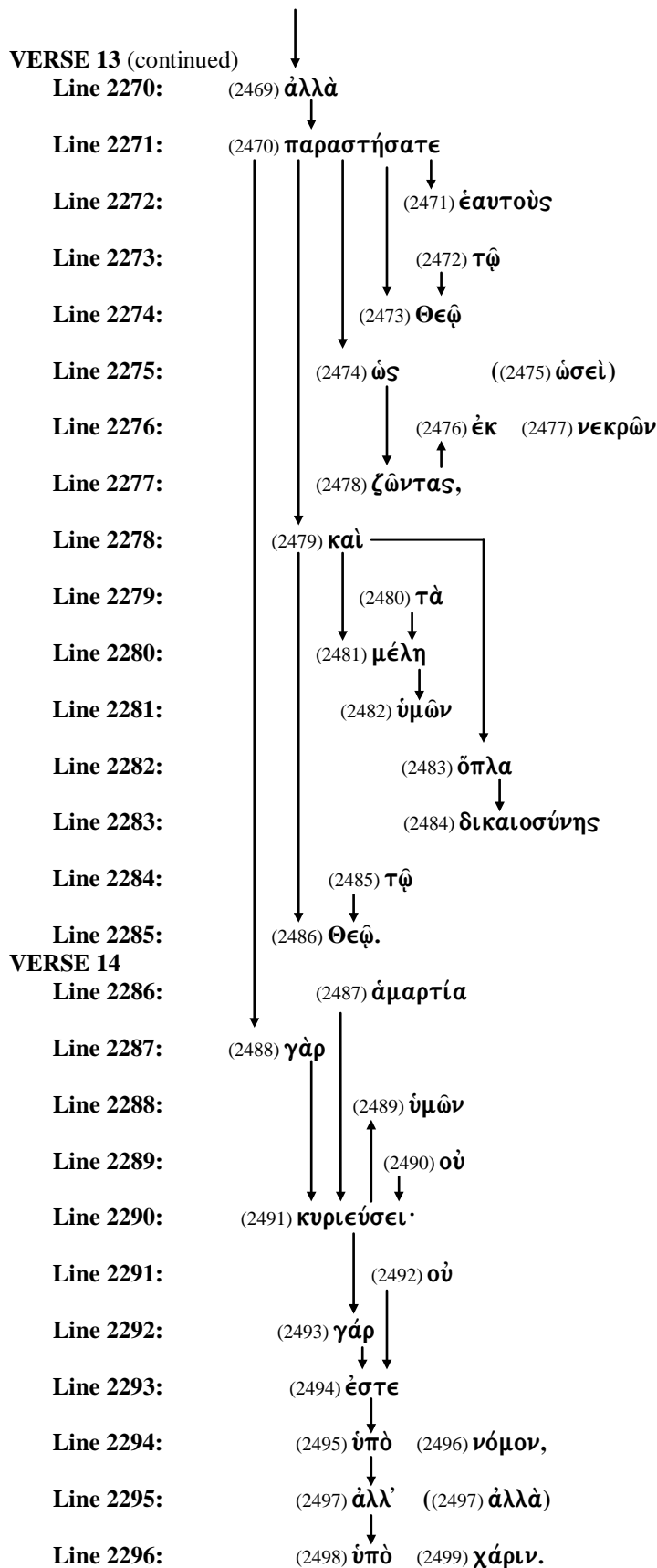

I Romans 1:1-17
The Introduction

II Romans 1:18-11:36
The Doctrine of the Christian Faith

Romans 1:18-3:20
The Indictment: The Doctrine of Condemnation

Romans 3:21-5:21
The Imputation: The Doctrine of Justification

Romans 6:1-8:39
The Impartation: The Doctrine of Sanctification

Romans chapters 6-7 are systematically arranged around four questions:

- 1) **Romans 6:1**
- 2) **Romans 6:15**
- 3) **Romans 7:7**
- 4) **Romans 7:13**

Romans 6	The Power over Sin	
	Romans 6:1-14	The Principles of Sanctification
	Romans 6:15-23	The Process of Sanctification
Romans 7	The Problem of the Flesh	
	Romans 7:1-6	The Precepts of Sanctification
	Romans 7:7-13	The Perception of Sanctification
	Romans 7:14-25	The Performance of Sanctification
Romans 8	The Provision of the Spirit	
	Romans 8:1-4	The Plan of Sanctification
	Romans 8:5-11	The Procedure of Sanctification
	Romans 8:12-17	The Product of Sanctification
	Romans 8:18-25	The Patience in Sanctification
	Romans 8:26-30	The Provision of Sanctification
	Romans 8:31-39	The Position in Sanctification

Lesson Twenty-Three

Romans 6:8-14

Diagrams

Romans 6:8 εἰ δὲ ἀπεθάνομεν σὺν Χριστῷ, πιστεύομεν ὅτι καὶ συζήσομεν αὐτῷ·

Romans 6:8 Diagram

Line 2191:

CONJ.
(2386) εἰ
if

Line 2192:

CONJ.
(2387) δὲ
and

Line 2193:

1P.PL.
2AOR.ACT.IND.(35)
(2388) ἀπεθάνομεν
we died

Line 2194:

PREP. DAT.S.M.
W/DAT.(18) 2DEC.N.(12)
(2389) σὺν (2390) Χριστῷ,
with Christ,

Line 2195:

1P.PL.
PRES.ACT.IND.(10)
(2391) πιστεύομεν
we believe

Line 2196:

CONJ.
(2392) ὅτι
that

Line 2197:

CONJ.
(2393) καὶ
also

Line 2198:

1P.PL.
FUT.ACT.IND.(31)
(2394) συζήσομεν
we will live with

Line 2199:

DAT.S.M.
3P.PERS.PRO.(20)
(2395) αὐτῷ·
Him;

(2386) **εἰ** - conjunction = if

(2387) **δὲ** - conjunction = and, now, even

(2388) **ἀποθνήσκω** = to die
from **ἀπό** - preposition = from
and **θνήσκω** = to be dead

(2389) **σύν** - preposition used with the dative = with, together

(2390) **Χριστός** = Christ
meaning “anointed” - from **χρίω** = to anoint

(2391) **πιστεύω** = to believe, to be persuaded
from **πίστις** = faith
from **πείθω** = to persuade

(2392) **ὅτι** - conjunction = that, because

(2393) **καί** - conjunction = and, also, even

(2394) **συζάω** = to live with
from **σύν** - preposition = with
and **ζάω** = to live

(2395) **αὐτός** - third person personal pronoun = he, she, it

Romans 6:9 Diagram

Romans 6:9 εἰδότες ὅτι Χριστὸς ἐγερθεὶς ἐκ νεκρῶν οὐκέτι ἀποθνήσκει· θάνατος αὐτοῦ οὐκέτι κυριεύει.

Line 2200:

NOM.PL.M.
PERF.ACT.PART.(54)
(2396) **εἰδότες**
knowing

Line 2201:

CONJ.
(2397) **ὅτι**
that

Line 2202:

NOM.S.M.
2DEC.N.(12)
(2398) **Χριστὸς**
Christ

Line 2203:

NOM.S.M.
AOR.PASS.PART.(45)
(2399) **ἐγερθεὶς**
having been raised

Line 2204:

PREP. GEN.PL.M.
W/GEN.(18) ADJ.(17)
(2400) **ἐκ** (2401) **νεκρῶν**
out of dead

Line 2205:

ADV.(67)
(2402) **οὐκέτι**
no longer

Line 2206:

3P.S.
PRES.ACT.IND.(10)
(2403) **ἀποθνήσκει·**
is dying;

Line 2207:

NOM.S.M.
2DEC.N.(12)
(2404) **θάνατος**
death

Line 2208:

GEN.S.M.
3P.PERS.PRO.(20)
(2405) **αὐτοῦ**
Him

Line 2209:

ADV.(67)
(2406) **οὐκέτι**
no longer

Line 2210:

3P.S.
PRES.ACT.IND.(10)
(2407) **κυριεύει.**
is lording over.

- (2396) **οἶδα** = to see, to perceive with the eyes; to perceive with the senses
- (2397) **ὅτι** - conjunction = that, because
- (2398) **Χριστός** = Christ
meaning “anointed” - from **χρίω** = to anoint
- (2399) **ἐγείρω** = rise, raise, to arouse, cause to rise
from **ἀγορά** = an assembly
- (2400) **ἐκ** - preposition used with the genitive = out of, from
- (2401) **νεκρός** - adjective = a dead one
from **νεκός** = a corpse, a dead body
- (2402) **οὐκέτι** - adverb = not yet, no longer
from **οὐ** - negative particle = no, not
and **ἔτι** - adverb = still, yet, longer
from **ἔτος** = a year
- (2403) **ἀποθνήσκω** = to die
from **ἀπό** - preposition = from
and **θνήσκω** = to be dead
- (2404) **θάνατος** = death
from **θνήσκω** = to die
- (2405) **αὐτός** - third person personal pronoun = he, she, it
- (2406) **οὐκέτι** - adverb = not yet, no longer
from **οὐ** - negative particle = no, not
and **ἔτι** - adverb = still, yet, longer
from **ἔτος** = a year
- (2407) **κυριεύω** = to lord or ruler over
from **κύριος** = lord, master

Romans 6:10 Diagram

Romans 6:10 ὁ γὰρ ἀπέθανε(ν), τῇ ἀμαρτίᾳ ἀπέθανεν ἐφάπαξ· ὁ δὲ ζῆ, ζῆ τῷ Θεῷ.

Line 2211:

ACC.S.N.
REL.PRO.(62)
(2408) ὃ
what

Line 2212:

CONJ.
(2409) γὰρ
for

Line 2213:

3P.S.
2AOR.ACT.IND.(35)
(2410) ἀπέθανε(ν),
He died,

Line 2214:

DAT.S.F.
ART.(13)

(2411) τῇ
the

Line 2215:

DAT.S.F.
1DEC.N.(15)

(2412) ἀμαρτία
to sin

Line 2216:

3P.S.
2AOR.ACT.IND.(35)

(2413) ἀπέθανεν
He died

Line 2217:

ADV.(67)

(2414) ἐφάπαξ·
once for all;

Line 2218:

ACC.S.N.
REL.PRO.(62)

(2415) ὃ
what

Line 2219:

CONJ.
(2416) δὲ
and

Line 2220:

3P.S.
PRES.ACT.IND.(10)

(2417) ζῆ,
He is living,

Line 2221:

3P.S.
PRES.ACT.IND.(10)

(2418) ζῆ
He is living

Line 2222:

DAT.S.M.
ART.(13)

(2419) τῷ
the

Line 2223:

DAT.S.M.
2DEC.N.(12)

(2420) Θεῷ.
to God.

- (2408) **ὅς** - relative pronoun = who, which, what
- (2409) **γάρ** - conjunction = for
- (2410) **ἀποθνήσκω** = to die
from **ἀπό** - preposition = from
and **θνήσκω** = to be dead
- (2411) **ὁ** - article = the
- (2412) **ἁμαρτία** = to miss the mark
from **ἁμαρτάνω** = sin, trespass
- (2413) **ἀποθνήσκω** = to die
from **ἀπό** - preposition = from
and **θνήσκω** = to be dead
- (2414) **ἐφάπαξ** - adverb = at once, once and for all
from **ἐπί** - preposition = upon, over
and **ἅπαξ** - adverb = once
from **ἅπας** - adjective = all, every, whole
from **α** - a particle of union = with
and **πᾶς** - adjective = all, every, whole
- (2415) **ὅς** - relative pronoun = who, which, what
- (2416) **δὲ** - conjunction = and, now, even
- (2417) **ζάω** = to live, to breathe
- (2418) **ζάω** = to live, to breathe
- (2419) **ὁ** - article = the
- (2420) **θεός** = God, deity

Romans 6:11 Diagram

Romans 6:11 οὕτω(ς) καὶ ὑμεῖς λογίζεσθε ἑαυτοὺς (εἶναι) νεκροὺς μὲν εἶναι τῇ ἁμαρτία, ζῶντας δὲ τῷ Θεῷ ἐν Χριστῷ Ἰησοῦ [τῷ Κυρίῳ ἡμῶν].

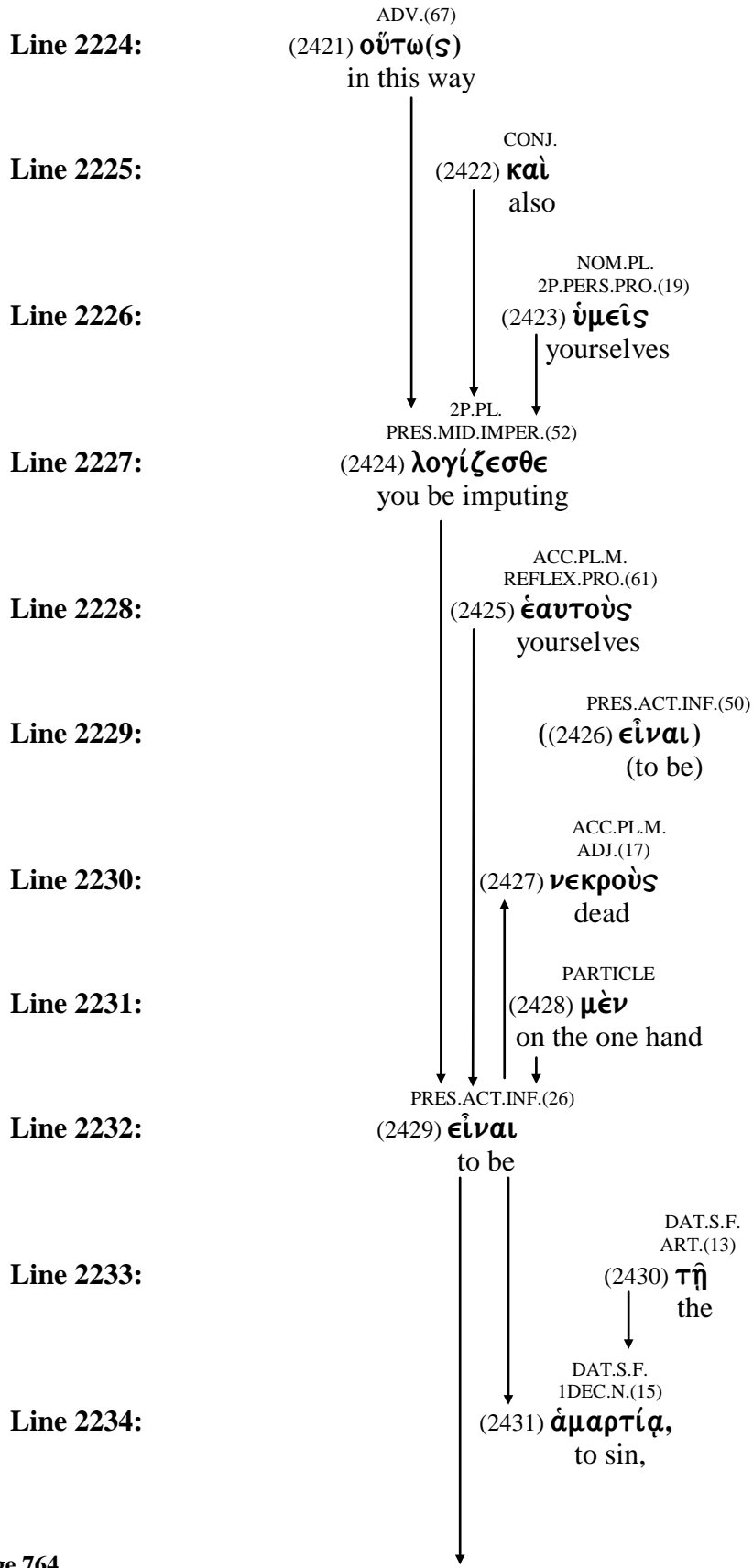

- (2421) **οὕτως** - adverb = so, thus, in this manner
from **οὗτος** - demonstrative pronoun = this
- (2422) **καί** - conjunction = and, also, even
- (2423) **σύ** - second person personal pronoun = you
- (2424) **λογίζομαι** = to reckon, count, compute, calculate
from **λόγος** = word, saying, account
- (2425) **ἑαυτοῦ** - reflexive pronoun = himself
from **αὐτός** - third person personal pronoun = he, she, it
- (2426) **εἰμί** = to be, exist
- (2427) **νεκρός** - adjective = a dead one
from **νεκός** = a corpse, a dead body
- (2428) **μέν** - particle = truly, certainly, indeed
- (2429) **εἰμί** = to be, exist
- (2430) **ὁ** - article = the
- (2431) **ἁμαρτία** = to miss the mark
from **ἁμαρτάνω** = sin, trespass

Romans 6:11 Diagram

Romans 6:11 οὕτω(ς) καὶ ὑμεῖς λογίζεσθε ἑαυτοὺς (εἶναι) νεκροὺς μὲν εἶναι τῇ ἁμαρτίᾳ, ζῶντας δὲ τῷ Θεῷ ἐν Χριστῷ Ἰησοῦ [τῷ Κυρίῳ ἡμῶν].

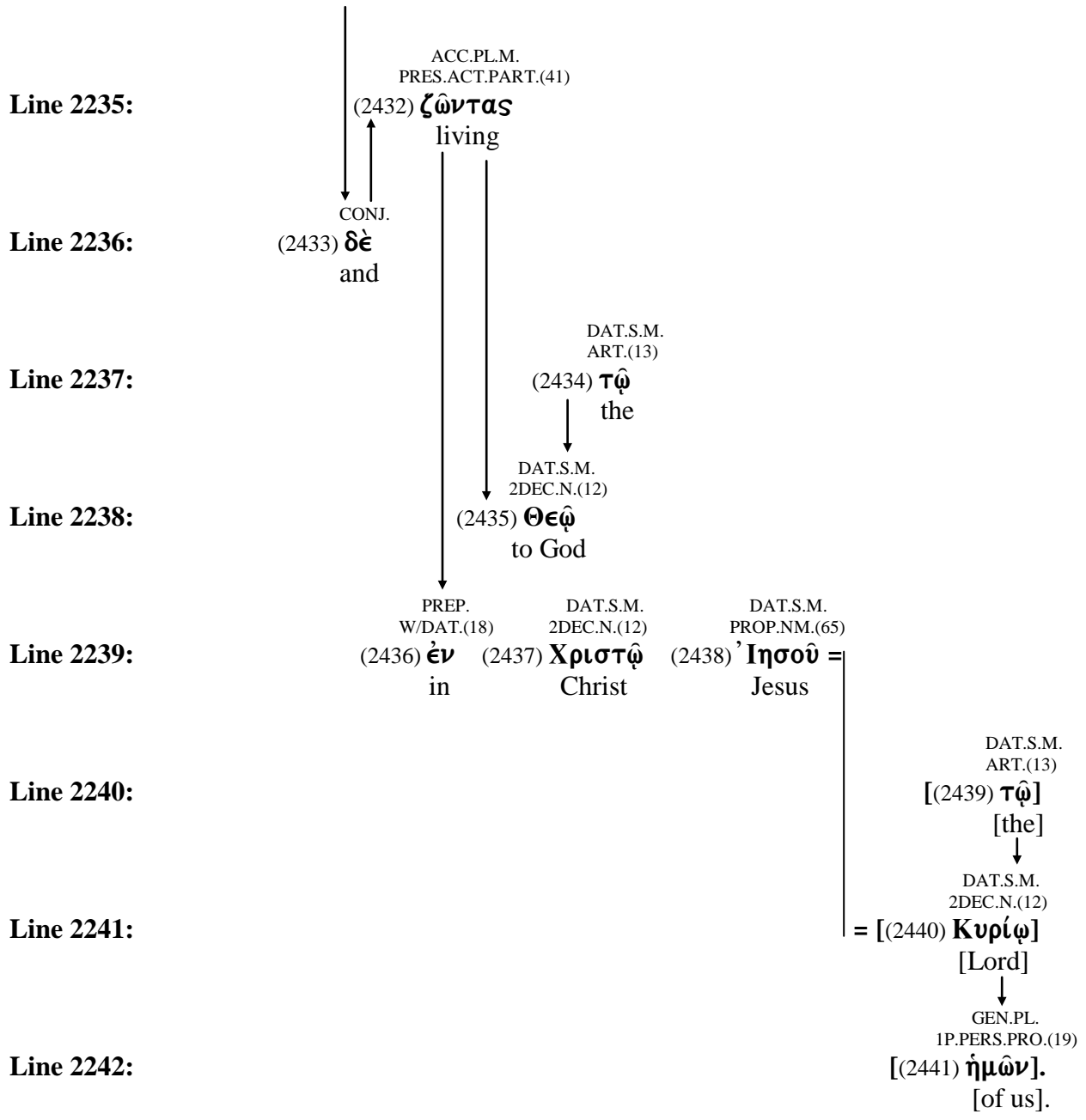

(2432) **ζάω** = to live, to breathe

(2433) **δέ** - conjunction = and, now, even

(2434) **ὁ** - article = the

(2435) **θεός** = God, deity

(2436) **ἐν** - preposition used with the dative = in

(2437) **Χριστός** = Christ
meaning “anointed” - from **χρίω** = to anoint

(2438) **Ἰησοῦς** = Jesus
of Hebrew origin - from **יְהוֹשֻׁעַ** = Joshua or Jehoshua = “Yahweh is salvation”
from **יְהוָה** = Yahweh = “the existing One”
from **הָיָה** = to be, become, come to
and **שָׁמַר** = to save, be saved, be delivered, to rescue

(2439) **ὁ** - article = the

(2440) **κύριος** = lord, master
from **κύρος** = supremacy

(2441) **ἐγώ** - first person personal pronoun = I

Romans 6:12 Diagram

Romans 6:12 Μὴ οὖν βασιλεύτω ἡ ἀμαρτία ἐν τῷ θνητῷ ὑμῶν σώματι, εἰς τὸ ὑπακούειν [αὐτῇ ἐν] ταῖς ἐπιθυμίαις αὐτοῦ·

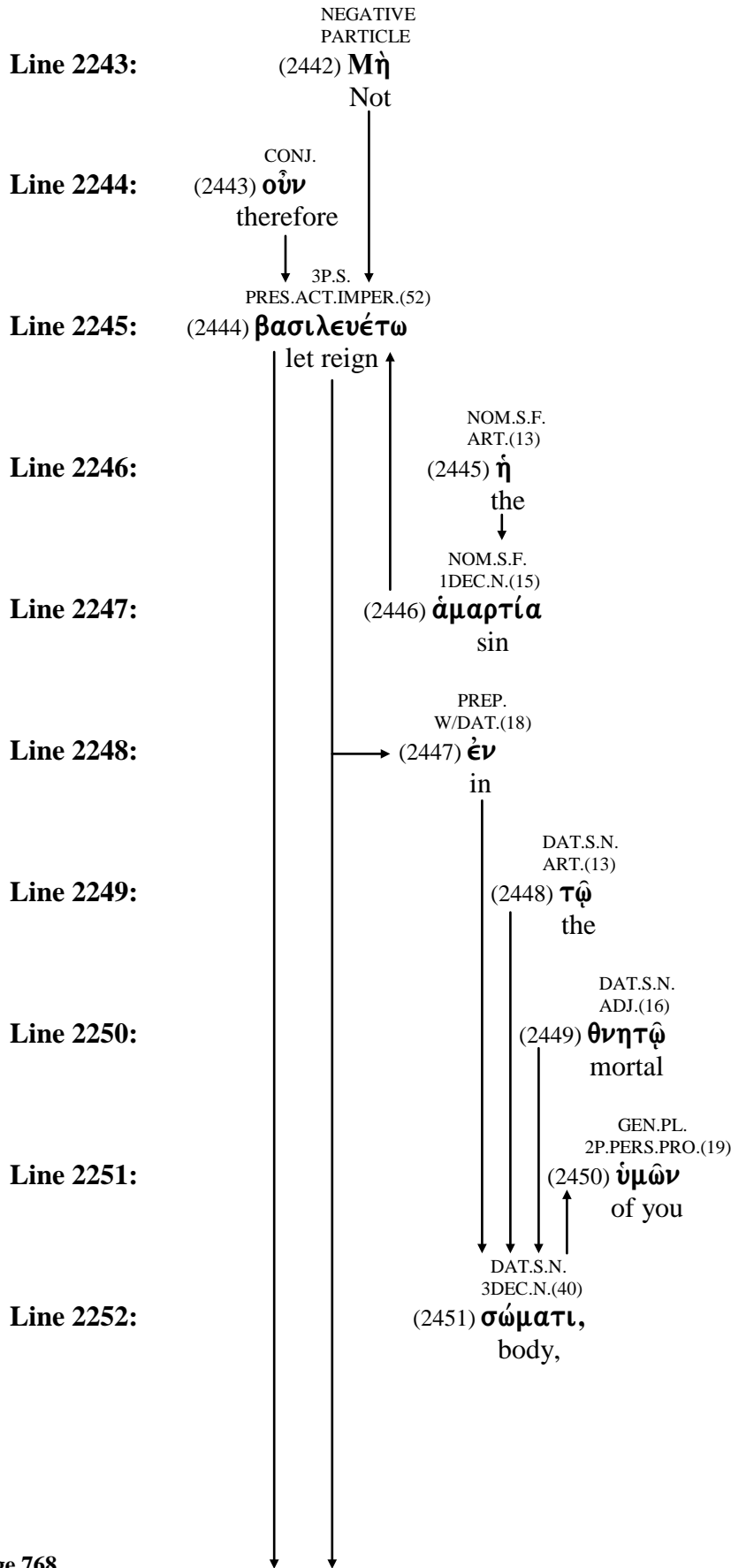

- (2442) μή - negative particle = no, not
- (2443) οὖν - particle = therefore, then
- (2444) βασιλεύω = to reign, to rule
from βασιλεύς = king
from βάσις = foot, feet
- (2445) ὁ - article = the
- (2446) ἁμαρτία = to miss the mark
from ἁμαρτάνω = sin, trespass
- (2447) ἐν - preposition used with the dative = in
- (2448) ὁ - article = the
- (2449) θνητός - adjective = mortal, human, susceptible to death
from θνήσκω = to die, to become dead
- (2450) σύ - second person personal pronoun = you
- (2451) σῶμα = body

Romans 6:12 Μὴ οὖν βασιλευέτω ἡ ἁμαρτία ἐν τῷ θνητῷ ὑμῶν
σώματι, εἰς τὸ ὑπακούειν [αὐτῇ ἐν] ταῖς ἐπιθυμίαις αὐτοῦ·

Romans 6:12 Diagram

Line 2253:

PREP.
W/ACC.(18)
(2452) εἰς
for

Line 2254:

ACC.S.N.
ART.(13)
(2453) τὸ
the

Line 2255:

PRES.ACT.INF.(50)
(2454) ὑπακούειν
to obey

Line 2256:

DAT.S.F.
3P.PERS.PRO.(20)
[(2455) αὐτῇ]
[it]

Line 2257:

PREP.
W/DAT.(18)
[(2456) ἐν]
[in]

Line 2258:

DAT.PL.F.
ART.(13)
(2457) ταῖς
the

Line 2259:

DAT.PL.F.
1DEC.N.(15)
(2458) ἐπιθυμίαις
lusts

Line 2260:

GEN.S.N.
3P.PERS.PRO.(20)
(2459) αὐτοῦ·
of it;

(2452) **εἰς** - preposition used with the accusative = to, unto, towards

(2453) **ὁ** - article = the

(2454) **ὑπακούω** = to listen under, to obey, to follow
from **ὑπό** - preposition = under, by
and **ἀκούω** = to hear

(2455) **αὐτός** - third person personal pronoun = he, she, it

(2456) **ἐν** - preposition used with the dative = in

(2457) **ὁ** - article = the

(2458) **ἐπιθυμία** = desire, lust
from **ἐπιθυμέω** = to desire, to long for
from **ἐπί** - preposition = upon
and **θυμός** = heat, passion, anger

(2459) **αὐτός** - third person personal pronoun = he, she, it

Romans 6:13 μηδὲ παριστάνετε τὰ μέλη ὑμῶν ὄπλα ἀδικίας τῇ ἀμαρτία· ἀλλὰ παραστήσατε ἑαυτοὺς τῷ Θεῷ ὡς (ὡσεὶ) ἐκ νεκρῶν ζῶντας, καὶ τὰ μέλη ὑμῶν ὄπλα δικαιοσύνης τῷ Θεῷ.

Romans 6:13 Diagram

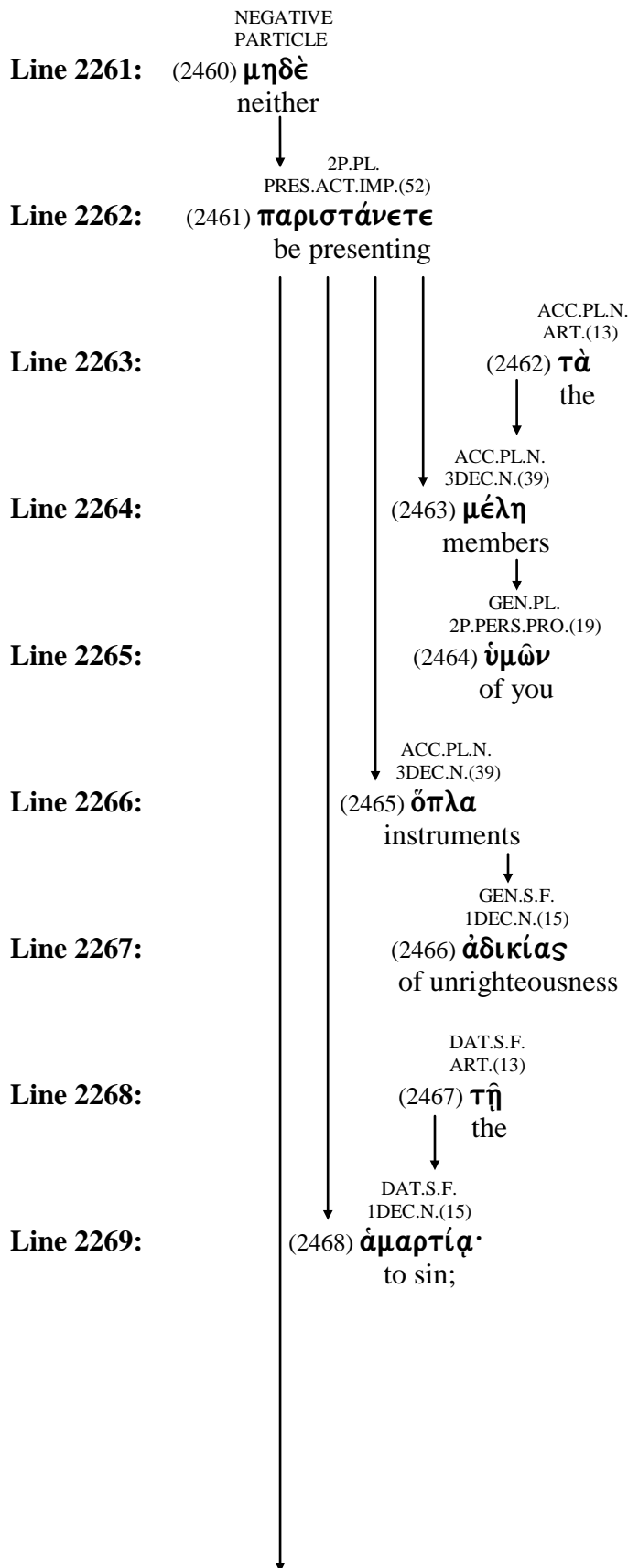

- (2460) **μηδέ** = not even, and not
from **μή** - negative particle = no, not
and **δέ** - conjunction = and, now, even
- (2461) **παρίστημι** = to place alongside of, to present
from **παρά** - preposition = from, along side of, near
and **ἵστημι** = to place, set, to cause to stand
- (2462) **ὁ** - article = the
- (2463) **μέλος** = a member, limb, any part of the body
- (2464) **σύ** - second person personal pronoun = you
- (2465) **ὄπλον** = a weapon, instrument, tool, armor
- (2466) **ἀδικία** = injustice, wrong, wrongdoing, unrighteous
from **ἄδικος** - adjective = unjust, unrighteous
from **α** - a particle of privation = without
and **δίκη** = justice, punishment
from **δεικνύω** = to show, to point out
- (2467) **ὁ** - article = the
- (2468) **ἁμαρτία** = to miss the mark
from **ἁμαρτάνω** = sin, trespass

Romans 6:13 μηδὲ παριστάνετε τὰ μέλη ὑμῶν ὄπλα ἀδικίας τῇ ἀμαρτία· ἀλλὰ παραστήσατε ἑαυτοὺς τῷ Θεῷ ὡς (ὡσεὶ) ἐκ νεκρῶν ζῶντας, καὶ τὰ μέλη ὑμῶν ὄπλα δικαιοσύνης τῷ Θεῷ.

Romans 6:13 Diagram

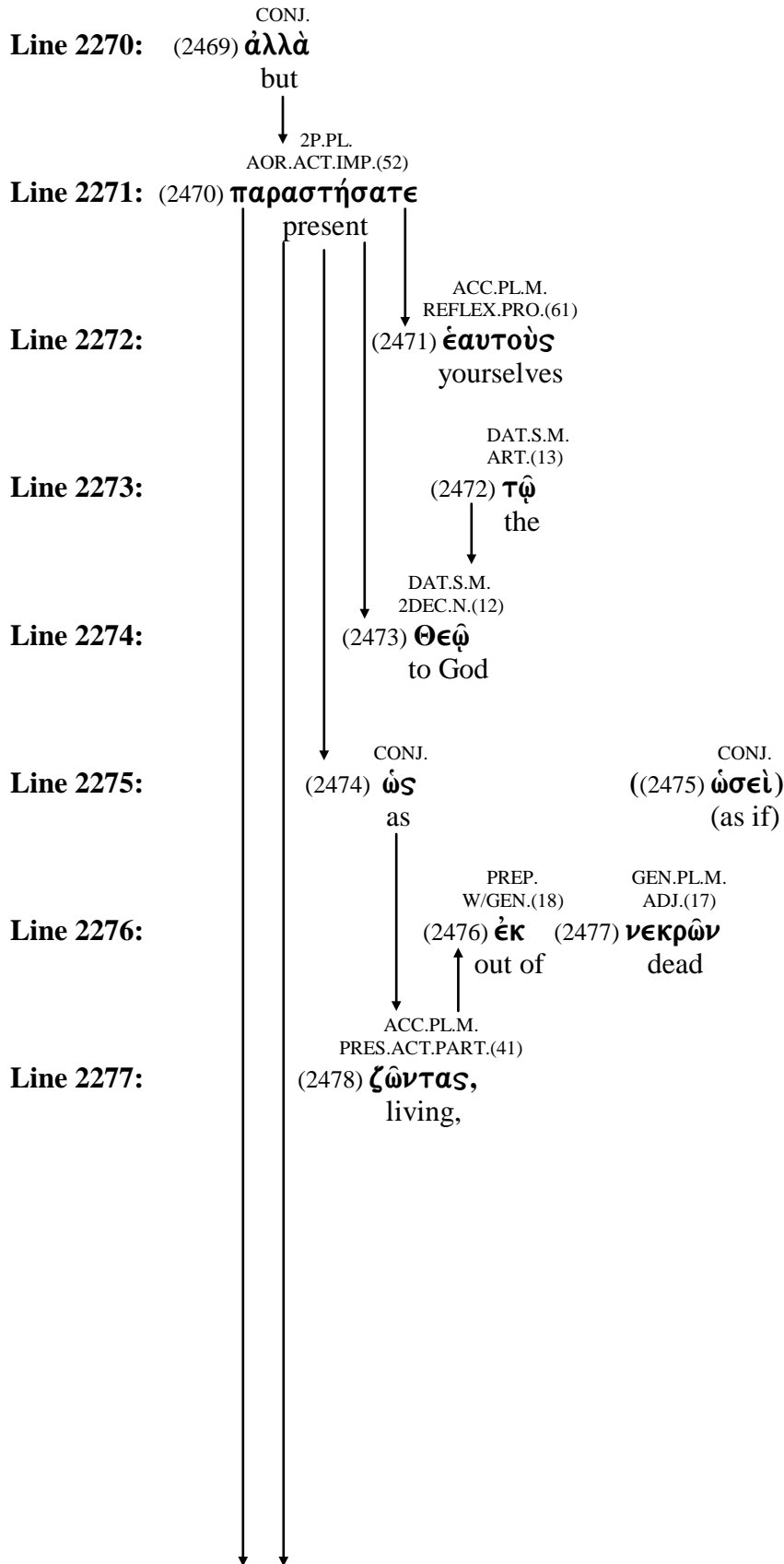

- (2469) **ἀλλά** - conjunction = but
- (2470) **παρίστημι** = to stand beside, to present
from **παρά** - preposition = alongside
and **ἵστημι** = to stand
- (2471) **ἑαυτοῦ** - reflexive pronoun = himself
from **αὐτός** - third person personal pronoun = he, she, it
- (2472) **ὁ** - article = the
- (2473) **θεός** = God, deity
- (2474) **ὡς** - adverb used as a comparative particle = as, like
from **ὅς** - relative pronoun = who, which, what
- (2475) **ὡσεὶ** - adverb = as if
from **ὡς** - adverb = as, like
and **εἰ** - conjunction = if
- (2476) **ἐκ** - preposition used with the genitive = out of, from
- (2477) **νεκρός** - adjective = a dead one
from **νεκός** = a corpse, a dead body
- (2478) **ζάω** = to be alive, to live

Romans 6:13 μηδὲ παριστάνετε τὰ μέλη ὑμῶν ὄπλα ἀδικίας τῇ ἀμαρτία· ἀλλὰ παραστήσατε ἑαυτοὺς τῷ Θεῷ ὡς (ὡσεὶ) ἐκ νεκρῶν ζῶντας, καὶ τὰ μέλη ὑμῶν ὄπλα δικαιοσύνης τῷ Θεῷ.

Romans 6:13 Diagram

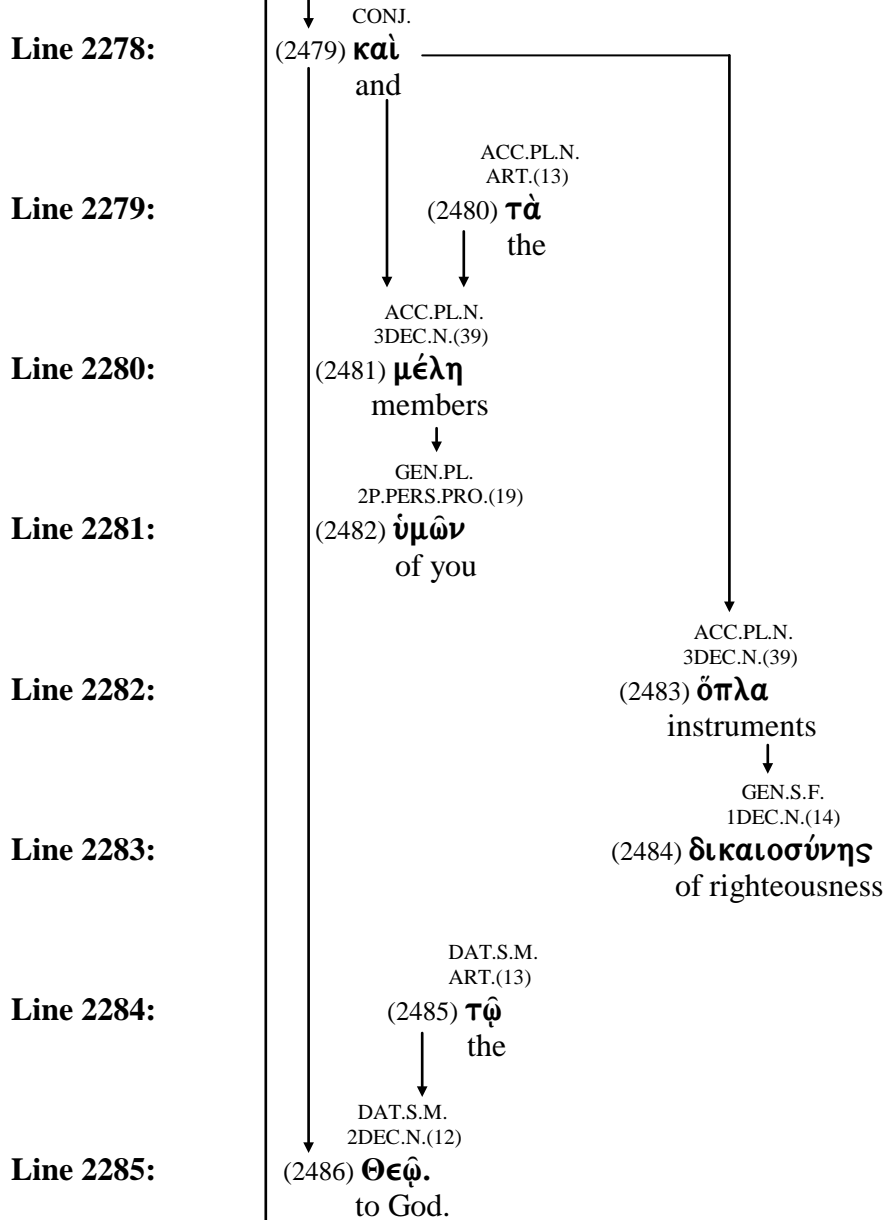

(2479) **καί** - conjunction = and, also, even

(2480) **ὁ** - article = the

(2481) **μέλος** = a member, limb, any part of the body

(2482) **σύ** - second person personal pronoun = you

(2483) **ὄπλον** = a weapon, instrument, tool, armor

(2484) **δικαιοσύνη** = righteousness, justice

from **δίκαιος** - adjective = righteous, just

from **δίκη** = justice, punishment

from **δεικνύω** = to show, to point out

(2485) **ὁ** - article = the

(2486) **θεός** = God, deity

Romans 6:14 ἁμαρτία γὰρ ὑμῶν οὐ κυριεύσει· οὐ γὰρ ἐστε ὑπὸ νόμον, ἀλλ' (ἀλλὰ) ὑπὸ χάριν.

Romans 6:14 Diagram

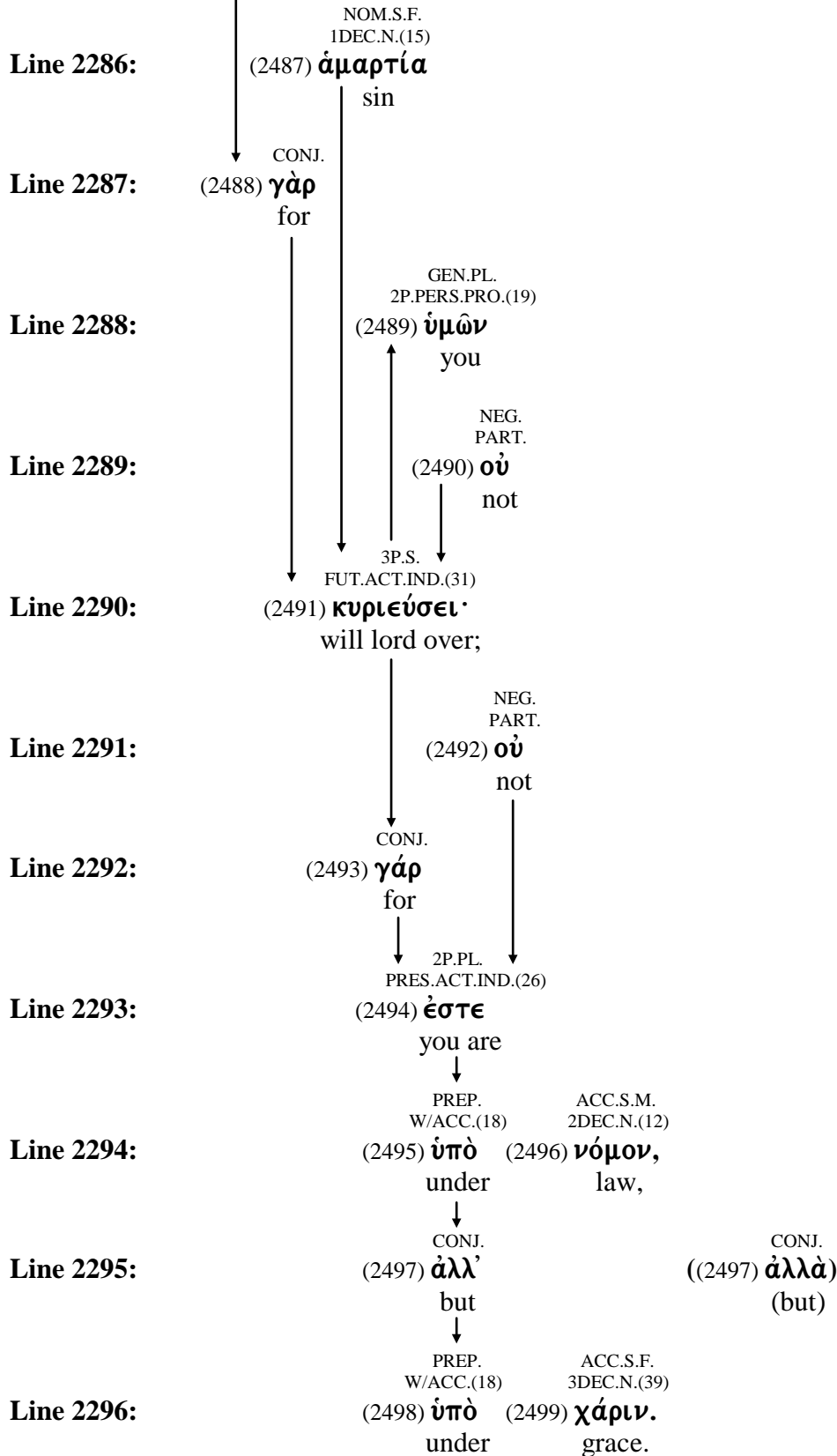

- (2487) **ἁμαρτία** = to miss the mark
from **ἁμαρτάνω** = sin, trespass
- (2488) **γάρ** - conjunction = for
- (2489) **σύ** - second person personal pronoun = you
- (2490) **οὐ** - negative particle = no, not
- (2491) **κυριεύω** = to lord or rule over
from **κύριος** = lord, master
- (2492) **οὐ** - negative particle = no, not
- (2493) **γάρ** - conjunction = for
- (2494) **εἰμί** = to be, exist
- (2495) **ὑπό** - preposition = by, under
- (2496) **νόμος** = a law, a command, anything established
- (2497) **ἄλλος** - adjective = another, other
- (2498) **ὑπό** - preposition = by, under
- (2499) **χάρις** = grace
from **χαίρω** = rejoice

