

Lesson Eight

Romans 2:12-16

Romans 2:12-16

Greek / English Interlinear

12) ὅσοι γὰρ ἀνόμως ἥμαρτον, ἀνόμως καὶ ἀπολοῦνται· καὶ
as many as for without law sinned, without law also will be destroyed; and

ὅσοι ἐν νόμῳ ἥμαρτον, διὰ νόμου κριθήσονται·
as many as in law sinned, through law will be judged;

13) οὐ γὰρ οἱ ἀκροαταὶ (τοῦ) νόμου δίκαιοι παρὰ [τῷ] Θεῷ, ἀλλ’
not for the hearers (the) of law justified with [the] God, but

οἱ ποιηταὶ (τοῦ) νόμου δικαιωθήσονται.
the doers (the) of law will be justified.

14) ὅταν γὰρ ἔθνη τὰ μὴ νόμον ἔχοντα φύσει τὰ τοῦ
whenever for Gentiles the ones not law having by nature the things the

νόμου ποιῆ (ποιῶσιν), οὗτοι νόμον μὴ ἔχοντες, ἑαυτοῖς
of law should do (should do), these law not having, to themselves

εἰσι(ν) νόμος·
are law;

Lesson Eight

Romans 2:12-16 Greek / English Interlinear

Page 231

- 15) οἵτινες ἐνδείκνυνται τὸ ἔργον τοῦ νόμου γραπτὸν ἐν ταῖς
who are demonstrating the work the of law written in the

καρδίαις αὐτῶν, συμμαρτυρούσης αὐτῶν τῆς συνειδήσεως, καὶ
hearts of them, bearing witness with of them the conscience, and

μεταξὺ ἀλλήλων τῶν λογισμῶν κατηγορούντων ἢ καὶ
among one another the reasonings accusing or also

ἀπολογουμένων,
defending,

- 16) ἐν ἡμέρᾳ ὅτε κρίνει ὁ Θεὸς τὰ κρυπτὰ τῶν ἀνθρώπων,
in day when is judging the God the hidden things the of men,

ἀνθρώπων, κατὰ τὸ εὐαγγέλιον μου, διὰ Ἰησοῦ Χριστοῦ.
of men, according to the gospel of me, through Jesus Christ.

Romans 2:12-16
Word Association Diagram

Verse 12

Line 635:

Line 636:

Line 637:

Line 638:

Line 639:

Line 640:

Line 641:

Line 642:

Line 643:

Line 644:

Line 645:

Line 646:

Line 647:

Verse 13

Line 648:

Line 649:

Line 650:

Line 651:

Line 652: ((745) τοῦ)

Line 653:

Line 654:

Line 655:

Line 656:

Line 657:

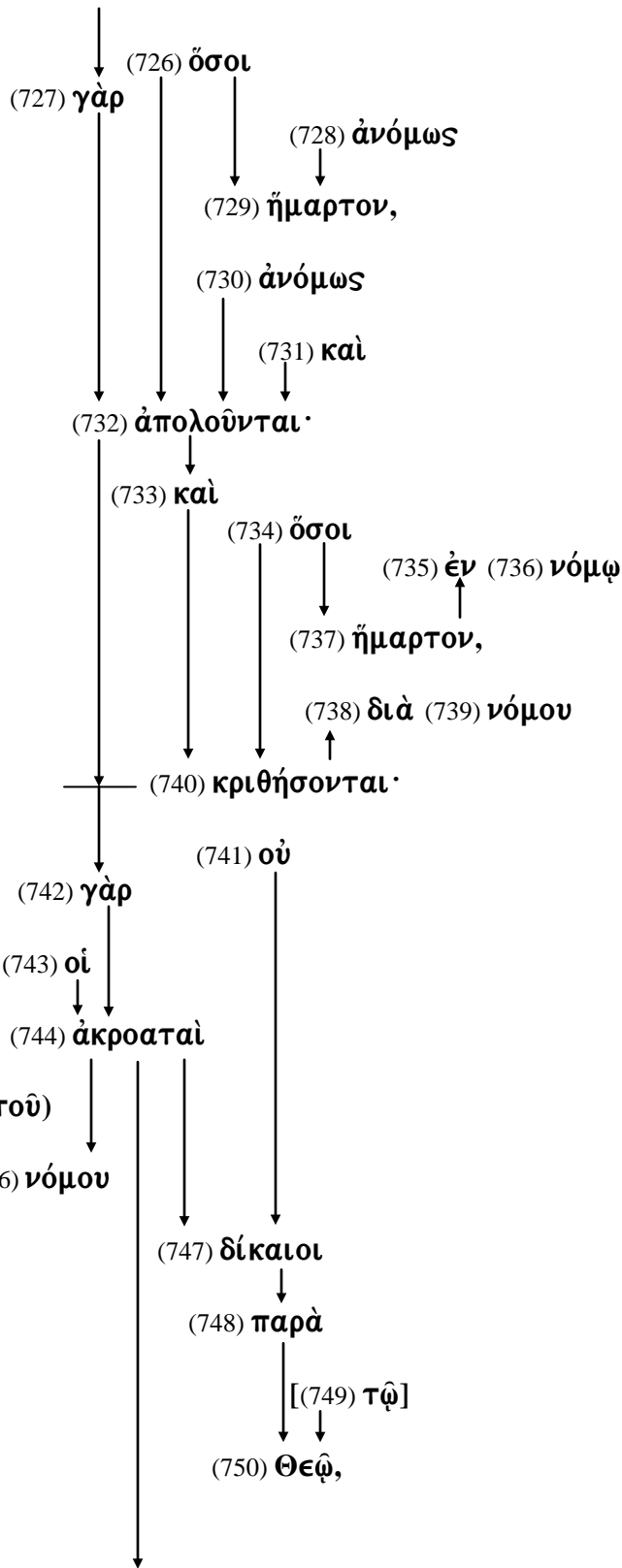

Lesson Eight
Romans 2:12-16 Word Association Diagram

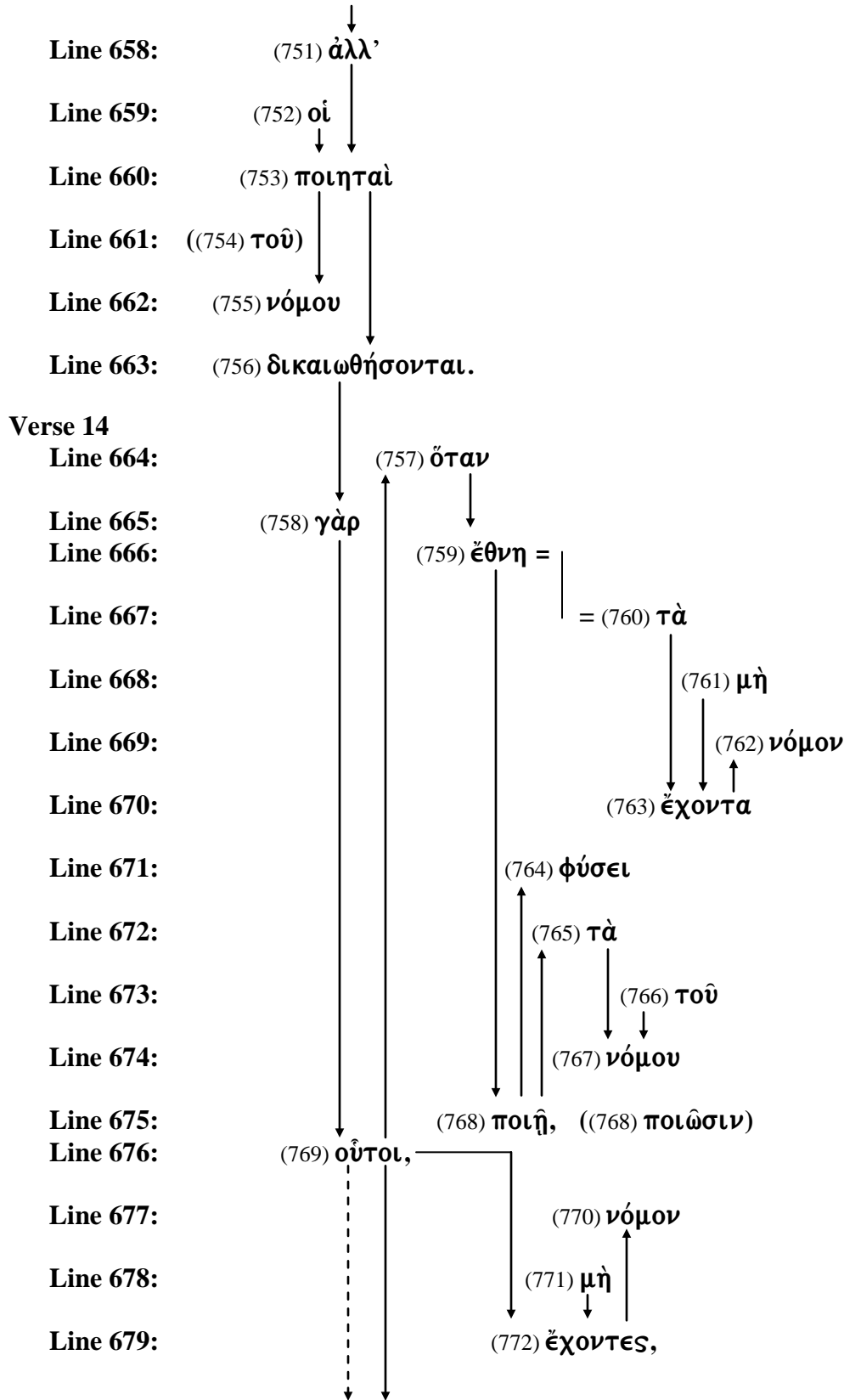

Romans 2:12-16

Word Association Diagram

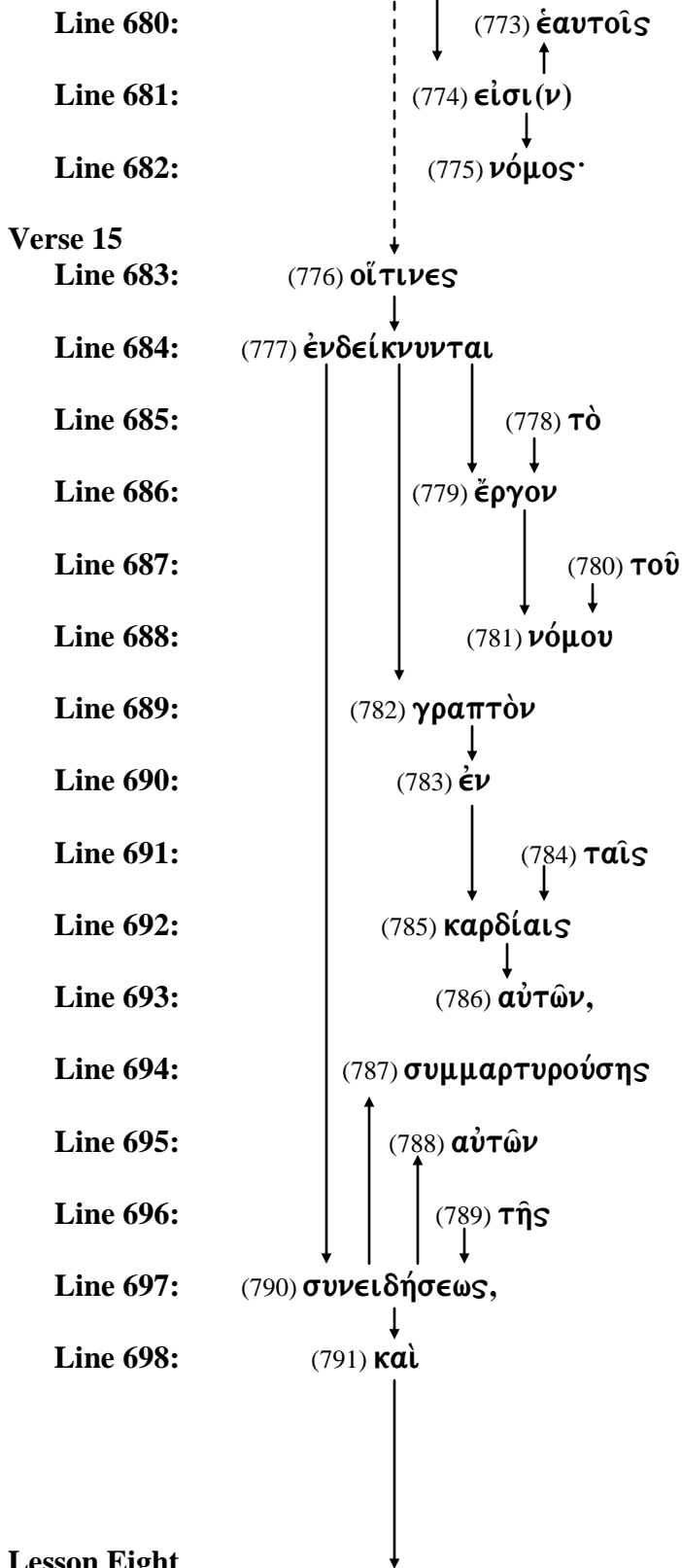

Lesson Eight

Romans 2:12-16 Word Association Diagram

Romans 2:12-16
Word Association Diagram

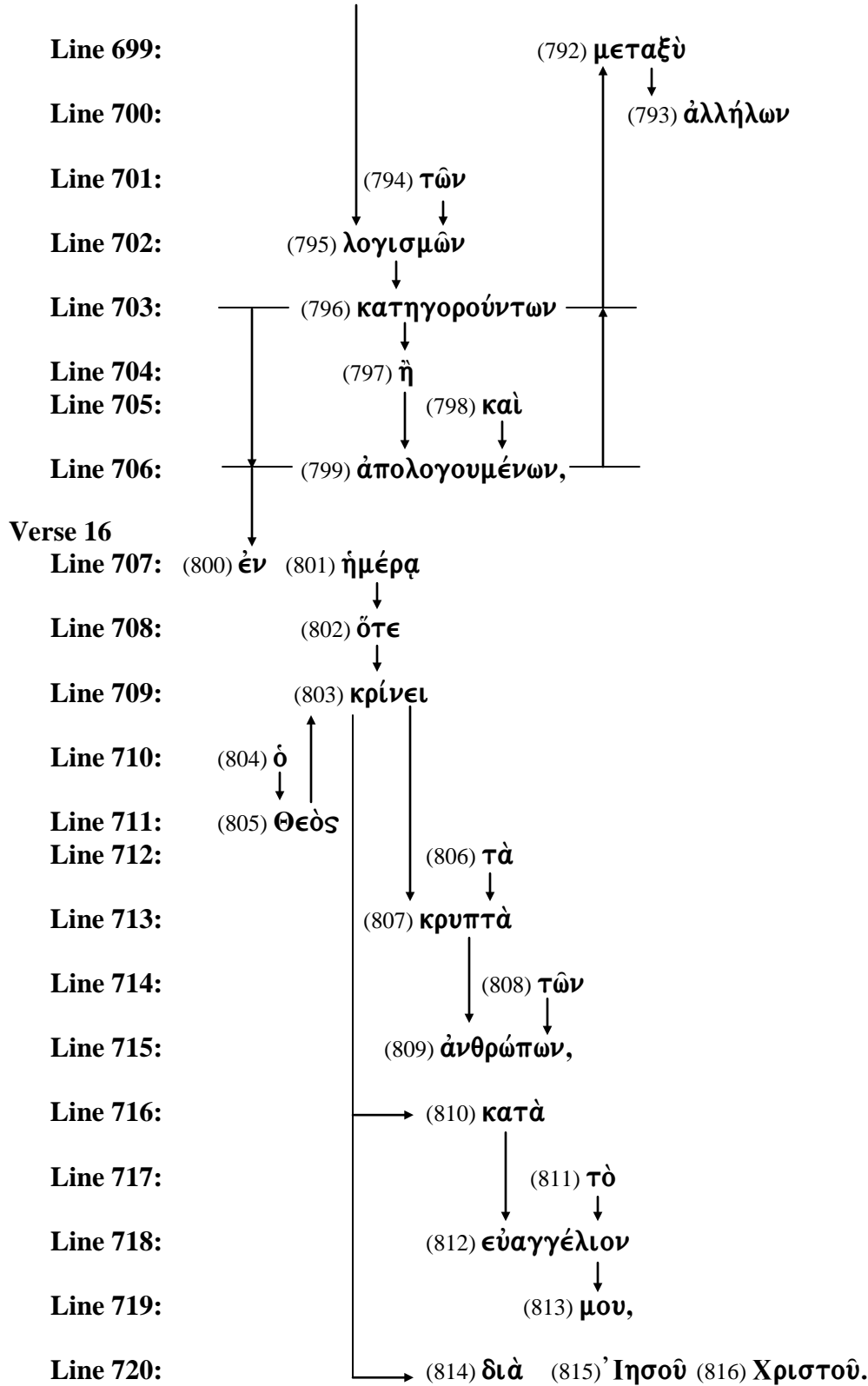

Lesson Eight

Romans 2:12-16

Diagrams

Romans 2:12-16
Verse 12 Diagram

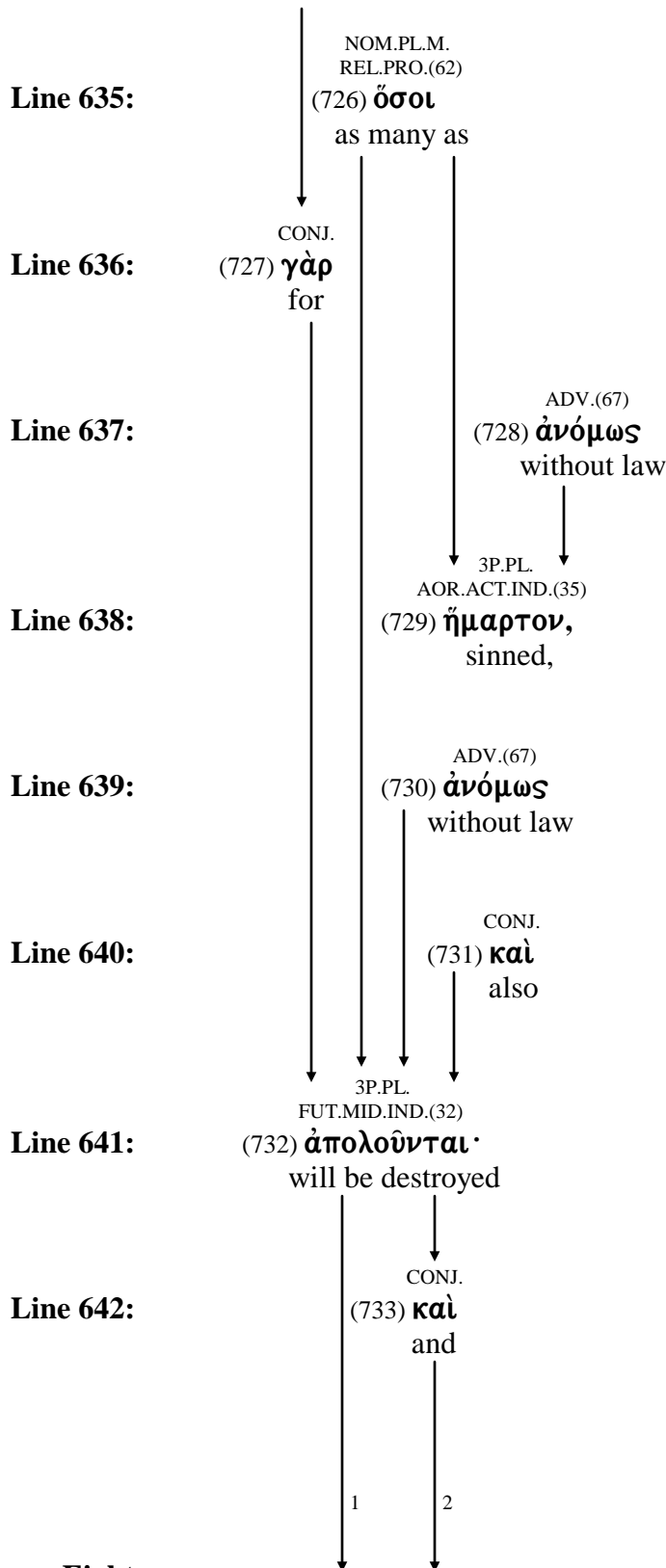

- (726) **ὅσος** - relative pronoun = as many as, as great as
from **ὅς** - relative pronoun = who, which, what
- (727) **γάρ** - conjunction = for
- (728) **ἀνόμως** - adverb = lawless, lawlessly, without law
from **ἄνομος** - adjective = lawless, lawlessness
from **α** - negative particle = without
and **νόμος** = law, to distribute or assign
- (729) **ἁμαρτάνω** = sin, trespass
- (730) **ἀνόμως** - adverb = lawless, lawlessly, without law
from **ἄνομος** - adjective = lawless, lawlessness
from **α** - negative particle = without
and **νόμος** = law, to distribute or assign
- (731) **καί** - conjunction = and, also, even
- (732) **ἀπόλλυμι** = to destroy, to perish
from **ἀπό** - preposition = from
and **ὄλεθρος** = destroy, destruction, ruin
- (733) **καί** - conjunction = and, also, even

Continued on page 242.

Romans 2:12-16
Verse 12 Diagram

Line 643:

1
 ↓ 2
 NOM.PL.M.
 REL.PRO.(62)
 (734) ὅσοι
 as many as

Line 644:

PREP. DAT.S.M.
 W/DAT.(18) 2DEC.N.(12)
 (735) ἐν (736) νόμῳ
 in law

Line 645:

3P.PL.
 AOR.ACT.IND.(35)
 (737) ἥμαρτον,
 sinned,

Line 646:

PREP. GEN.S.M.
 W/GEN.(18) 2DEC.N.(12)
 (738) διὰ (739) νόμου
 through law

Line 647:

3P.PL.
 FUT.PASS.IND.(38)
 (740) κριθήσονται·
 will be judged;

3
 ↓

Romans 2:12-16
Verse 12 Word Study

(734) **ὅσος** - relative pronoun = as many as, as great as
from **ὅς** - relative pronoun = who, which, what

(735) **ἐν** - preposition used with the dative = in

(736) **νόμος** = a law, a command, anything established

(737) **ἁμαρτάνω** = sin, trespass

(738) **διά** - preposition used with the genitive = through

(739) **νόμος** = a law, a command, anything established

(740) **κρίνω** = to judge, to determine; to separate

Romans 2:12-16
Verse 13 Diagram

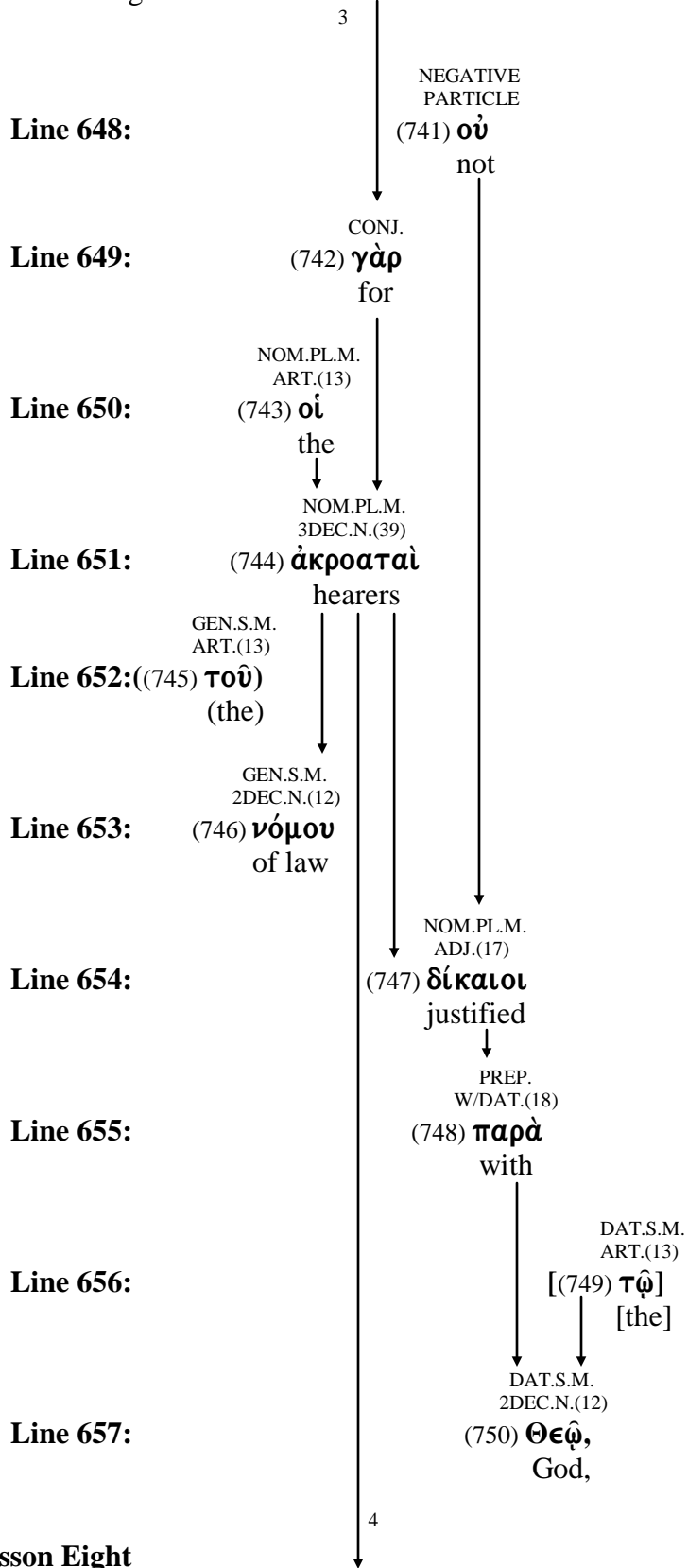

Lesson Eight
Romans 2:13 Diagram
Page 243

Romans 2:12-16
Verse 13 Word Study

- (741) **οὐ** - negative particle = no, not
- (742) **γάρ** - conjunction = for
- (743) **ὁ** - article = the
- (744) **ἀκροατής** = a hearer, one who hears
from **ἀκούω** = to hear
- (745) **ὁ** - article = the
- (746) **νόμος** = a law, a command, anything established
- (747) **δίκαιος** = righteous, just, right
from **δίκη** = judgment, execution of a sentence, punishment
- (748) **παρά** - preposition used with the dative = from, along side of, near
- (749) **ὁ** - article = the
- (750) **θεός** = God, deity

Continued on page 246.

Romans 2:12-16
Verse 13 Diagram

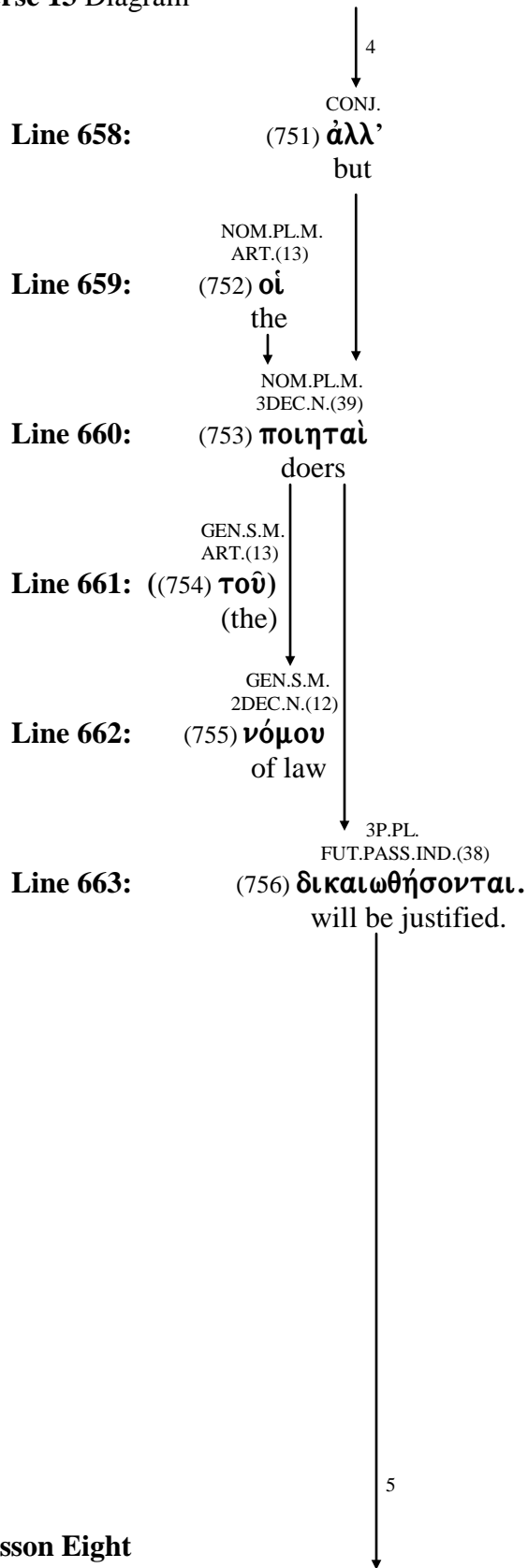

(751) **ἀλλά** - conjunction = but

(752) **ὁ** - article = the

(753) **ποιητής** = doer, maker, poet
from **ποιέω** = to do

(754) **ὁ** - article = the

(755) **νόμος** = a law, a command, anything established

(756) **δικαιόω** = to justify, to pronounce righteous
from **δίκαιος** - adjective = righteous, just
from **δίκη** = just, righteous, punishment
from **δεικνύω** = to show, to demonstrate

Romans 2:12-16
Verse 14 Diagram

Line 664:

5
 CONJ.
 (757) ὅταν
 whenever

Line 665:

CONJ.
 (758) γὰρ
 for

Line 666:

NOM.PL.N.
 3DEC.N.(12)
 (759) ἔθνη =
 Gentiles

Line 667:

NOM.PL.N.
 ART.(13)
 = (760) τὰ
 the ones

Line 668:

NEGATIVE
 PARTICLE
 (761) μὴ
 not

Line 669:

ACC.S.M.
 2DEC.N.(12)
 (762) νόμον
 law

Line 670:

NOM.PL.N.
 PRES.ACT.PART.(41)
 (763) ἔχοντα
 having

6 7 8

(757) **ὅταν** – particle used as a conjunction = whenever
from **ὅτε** - particle = when
and **ἄν** - particle used as a supposition or possibility = ever

(758) **γάρ** - conjunction = for

(759) **ἔθνος** = gentiles, a nation, a multitude
from **ἔθος** = custom, usage

(760) **ὁ** - article = the

(761) **μή** - negative particle = no, not

(762) **νόμος** = a law, a command, anything established

(763) **ἔχω** = to have, to hold

Continued on page 250.

Romans 2:12-16
Verse 14 Diagram

Line 671:

DAT.S.F.
 1DEC.N.(16)
 (764) φύσει
 by nature

Line 672:

ACC.PL.N.
 ART.(13)
 (765) τὰ
 the things

Line 673:

GEN.S.M.
 ART.(13)
 (766) τοῦ
 the

Line 674:

GEN.S.M.
 2DEC.N.(12)
 (767) νόμου
 of law

Line 675:

3P.S.
 PRES.ACT.SUBJ.(47)
 (768) ποιῆ,
 should do,

3P.PL.
 PRES.ACT.SUBJ.(47)
 ((768) ποιῶσιν)
 (should do)

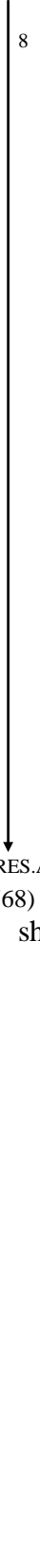
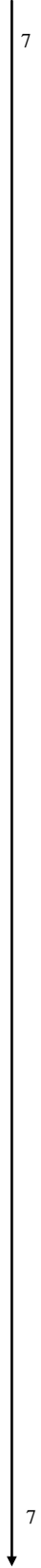
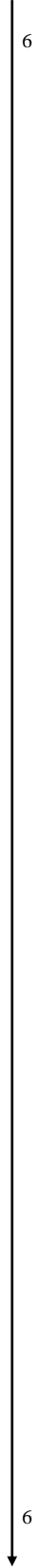

Romans 2:12-16
Verse 14 Word Study

(764) **φύσις** = nature, natural condition, species
from **φύω** = to grow
from **φύω** = to swell

(765) **ὁ** - article = the

(766) **ὁ** - article = the

(767) **νόμος** = a law, a command, anything established

(768) **ποιέω** = to make, to do

Continued on page 252.

Romans 2:12-16
Verse 14 Diagram

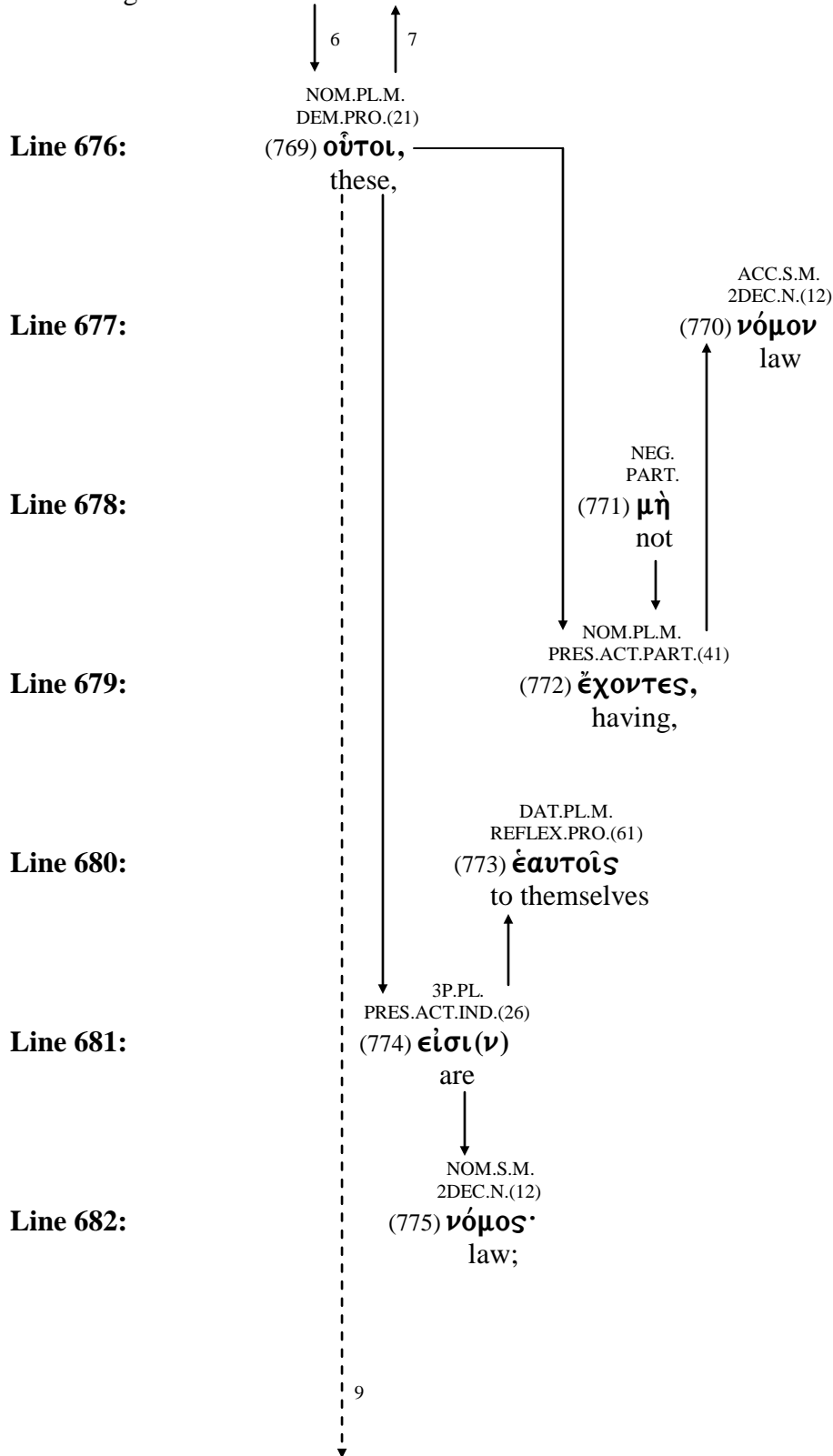

Lesson Eight
Romans 2:14 Diagram
Page 251

Romans 2:12-16
Verse 14 Word Study

(769) **οὗτος** - demonstrative pronoun = this

(770) **νόμος** = a law, a command, anything established

(771) **μή** - negative particle = no, not

(772) **ἔχω** = to have, to hold

(773) **ἑαυτοῦ** - reflexive pronoun = himself

from **αὐτός** - third person personal pronoun = he, she, it

(774) **εἰμί** = to be, exist

(775) **νόμος** = a law, a command, anything established

Romans 2:12-16
Verse 15 Diagram

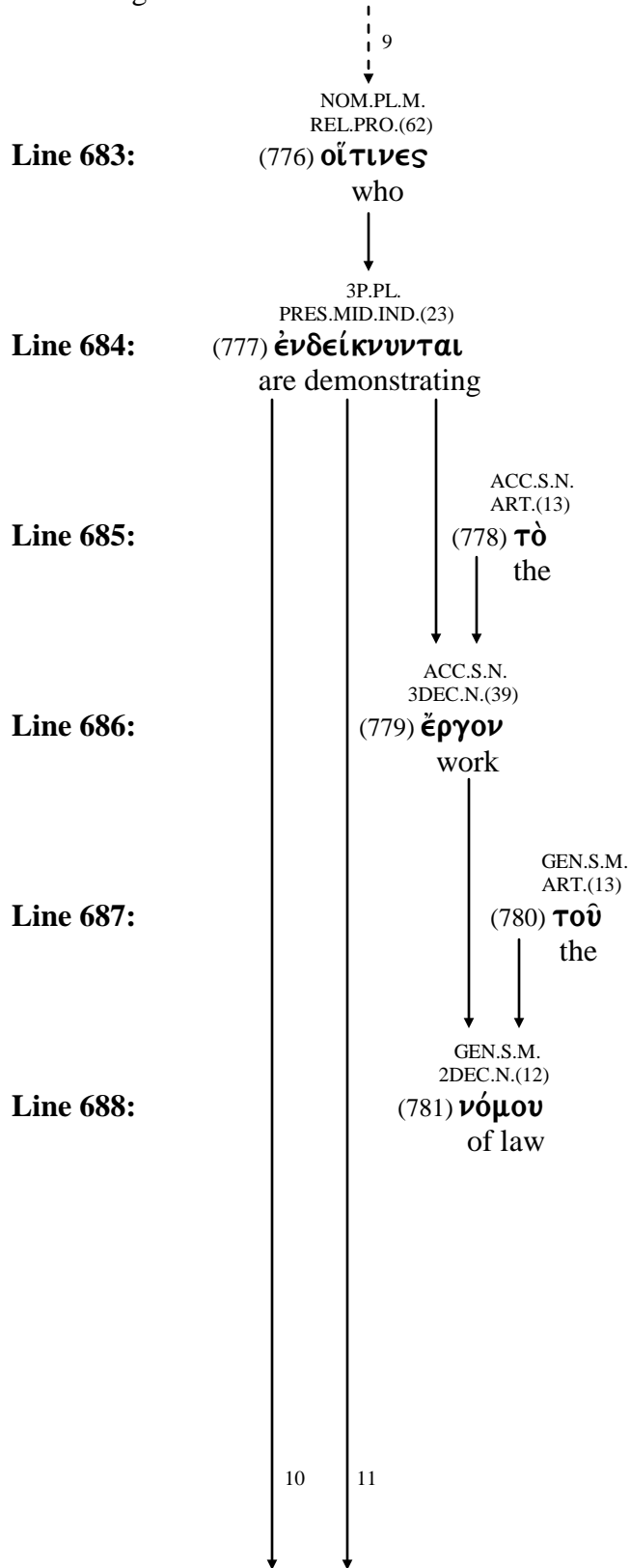

Lesson Eight
Romans 2:15 Diagram
Page 253

(776) **ὅστις** - indefinite relative pronoun = whoever, whatever, whichever
from **ὅς** - relative pronoun = who, which, what
and **τις** - indefinite pronoun = someone, a certain one

(777) **ἐνδείκνυμι** = to point out, to show, to demonstrate
from **ἐν** - preposition = in
and **δεικνύω** = to show, to demonstrate

(778) **ὁ** - article = the

(779) **ἔργον** = to work, to labor

(780) **ὁ** - article = the

(781) **νόμος** = a law, a command, anything established

Continued on page 256.

Romans 2:12-16
Verse 15 Diagram

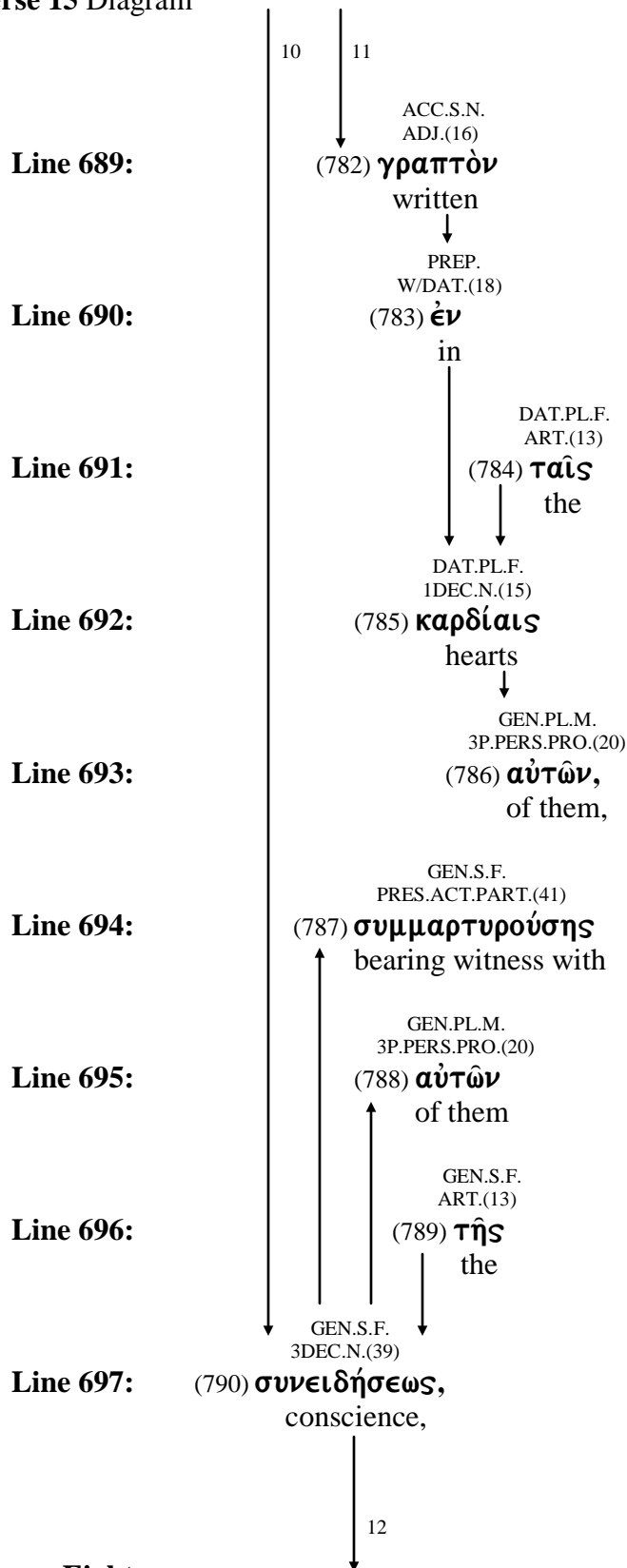

- (782) **γραπτός** - adjective = written
from **γράφω** = to write
- (783) **ἐν** - preposition used with the dative = in
- (784) **ὁ** - article = the
- (785) **καρδία** = heart
- (786) **αὐτός** - third person personal pronoun = he, she, it
- (787) **συμμαρτυρέω** = to witness with, to testify with
from **σύν** - preposition = with
and **μαρτυρέω** = to witness, to testify, to present evidence
- (788) **αὐτός** - third person personal pronoun = he, she, it
- (789) **ὁ** - article = the
- (790) **συνείδησις** = conscience, consciousness
from **συνείδω** = to consider
from **σύν** - preposition = with
from **οἶδα** = to know, to see, to consider

Continued on page 258.

Romans 2:12-16
Verse 15 Diagram

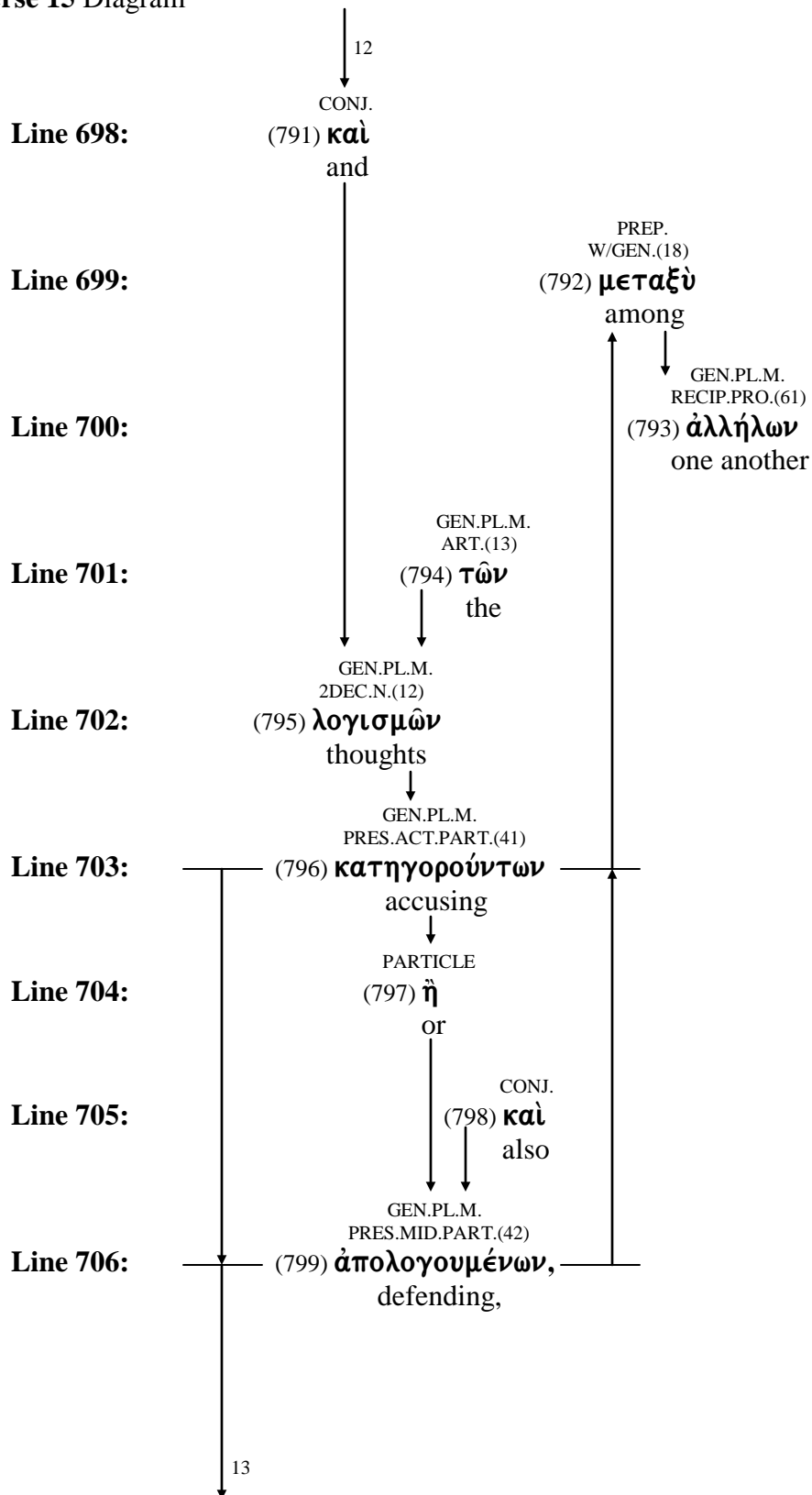

Lesson Eight
Romans 2:15 Diagram
Page 257

- (791) **καί** - conjunction = and, also, even
- (792) **μεταξύ** - adverb = in the midst, between, next
from **μετά** - preposition = association, succession
and **σύν** = preposition = with
- (793) **ἀλλήλων** - reciprocal pronoun = one another, reciprocally, mutually
from **ἄλλος** - adjective = another, other
- (794) **ὁ** - article = the
- (795) **λογισμός** = thoughts, reasoning, calculation
from **λογίζομαι** = to think, account, consider, reckon
from **λόγος** = word, speech, communicate
from **λέγω** = to say, to call, to invite
- (796) **κατηγορέω** = to speak against, to accuse
from **κατήγορος** = accuser
from **κατά** - preposition = against
and **ἀγορά** = market, marketplace
from **ἐγείρω** = to raise
- (797) **ἢ** - particle used as a conjunction = or
- (798) **καί** - conjunction = and, also, even
- (799) **ἀπολογέομαι** = to speak in defense
from **ἀπό** - preposition = from
and **λόγος** = word, speech, communicate
from **λέγω** = to say, to call, to invite

Romans 2:12-16
Verse 16 Diagram

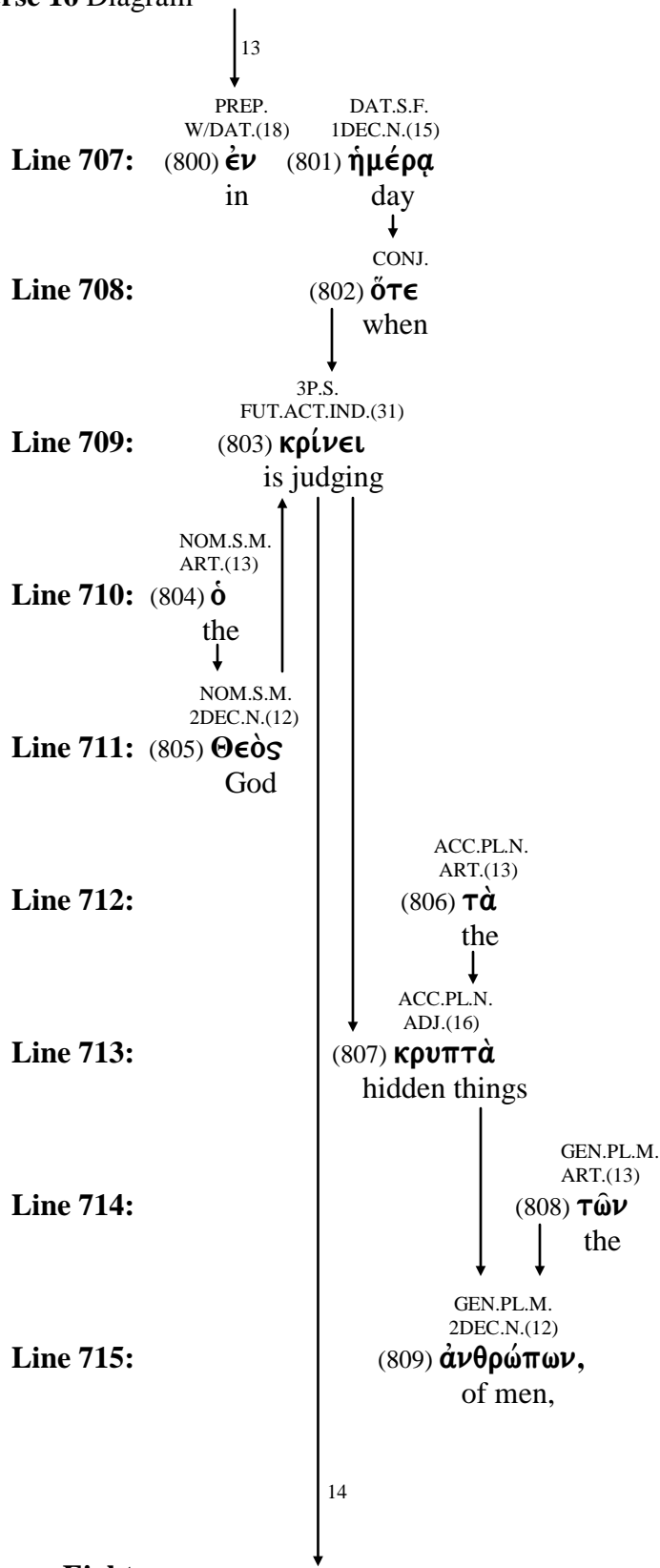

Lesson Eight
Romans 2:16 Diagram
Page 259

- (800) **ἐν** - preposition used with the dative = in
- (801) **ἡμέρα** = a day
- (802) **ὅτε** - conjunction = when
from **ὅς** - relative pronoun = who, which, what
- (803) **κρίνω** = to judge, to determine; to separate
- (804) **ὁ** - article = the
- (805) **θεός** = God, deity
- (806) **ὁ** - article = the
- (807) **κρυπτός** - adjective = hidden, concealed, secret
from **κρύπτω** = to hide, to do something secretly
- (808) **ὁ** - article = the
- (809) **ἄνθρωπος** = a man, a human being
from **ἄνῆρ** = a male
and **ὄψ** = the face or countenance

Continued on page 262.

Romans 2:12-16
Verse 16 Diagram

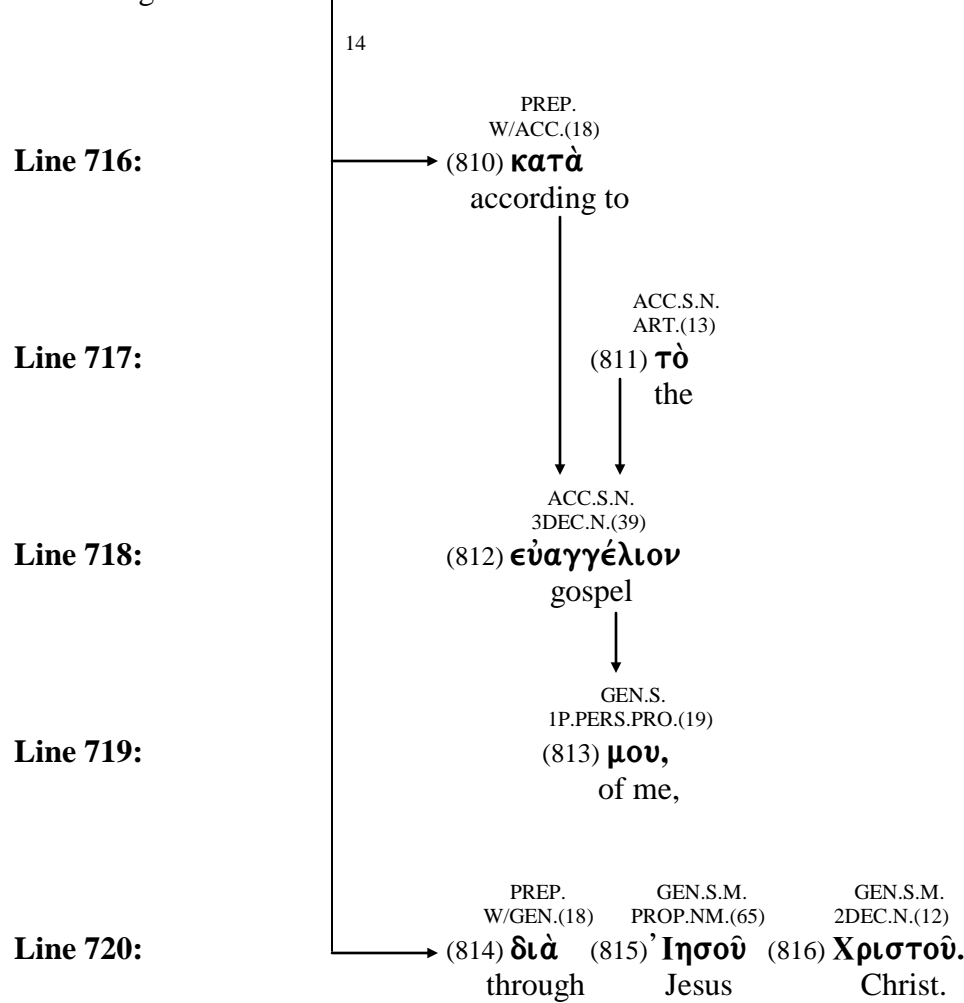

Lesson Eight
Romans 2:16 Diagram
Page 261

- (810) **κατὰ** - preposition used with the accusative = according to
- (811) **ὁ** - article = the
- (812) **εὐαγγέλιον** = good message, the gospel
from **εὖ** - adverb = well, prosper
and **ἄγγελος** = a messenger, an angel
- (813) **ἐγώ** - first person personal pronoun = I
- (814) **διὰ** - preposition used with the genitive = through
- (815) **Ἰησοῦς** = Jesus
of Hebrew origin - from ['nuwħoyð = Joshua or Jehoshua = “Yahweh is salvation”
from hwhy = Yahweh = “the existing One”
from hy:h; = to be, become, come to
and [v'ycæ = to save, be saved, be delivered, to rescue
- (816) **Χριστός** = Christ
meaning “anointed” - from **χρίω** = to anoint

