

Lesson Three

Romans 1:18-23

Romans 1:18-23

Greek / English Interlinear

18) Ἐποκαλύπτεται γὰρ ὀργὴ Θεοῦ ἀπὸ οὐρανοῦ ἐπὶ πᾶσαν
Is being revealed for wrath of God from heaven upon all

ἀσέβειαν καὶ ἀδικίαν ἀνθρώπων τῶν τὴν ἀλήθειαν ἐν
irreverence and unrighteousness of men the ones the truth in

ἀδικία κατεχόντων.
unrighteousness holding down.

19) διότι τὸ γνωστὸν τοῦ Θεοῦ φανερόν ἐστιν ἐν
on account of that the known the of God manifest is in

αὐτοῖς· ὁ (Θεὸς) γὰρ Θεὸς αὐτοῖς ἐφάνερωσε(ν).
them; the (God) for God to them manifested.

20) τὰ γὰρ ἀόρατα αὐτοῦ ἀπὸ κτίσεως κόσμου τοῖς
the things for invisible of him from creation of world the things

ποιήμασι(ν) νοούμενα καθαράται, ἢ τε αἰδῖος αὐτοῦ
being made being perceived are being clearly seen, the both eternal of Him

δύναμις καὶ θεϊότης, εἰς τὸ εἶναι αὐτοὺς ἀναπολογήτους·
power and divinity, for the to be them without excuse;

Lesson Three

Romans 1:18-23 Greek / English Interlinear

Page 78

21) διότι γνόντες τὸν Θεὸν, οὐχ ὡς Θεὸν ἐδόξασαν ἢ
on account of that having known the God, not as God they glorified nor

εὐχαρίστησαν, (ἠευχαρίστησαν) ἀλλ' ἐματαιώθησαν ἐν τοῖς
became thankful, (became thankful) but became empty in the

διαλογισμοῖς αὐτῶν, καὶ ἐσκοτίσθη ἡ ἀσύνετος αὐτῶν
reasonings of them, and was darkened the without understanding of them

καρδία.
heart;

22) φάσκοντες εἶναι σοφοὶ ἐμωράνθησαν,
professing to be wise they became fools,

23) καὶ ἠλλαξαν τὴν δόξαν τοῦ ἀφθάρτου Θεοῦ ἐν ὁμοιώματι
and they changed the glory the incorruptible of God in likeness

εἰκόνης φθαρτοῦ ἀνθρώπου καὶ πετεινῶν καὶ τετραπόδων
of image corruptible of man and of birds and of four footed creatures

καὶ ἐρπετῶν.
and of reptiles.

Romans 1:18-23
Word Association Diagram

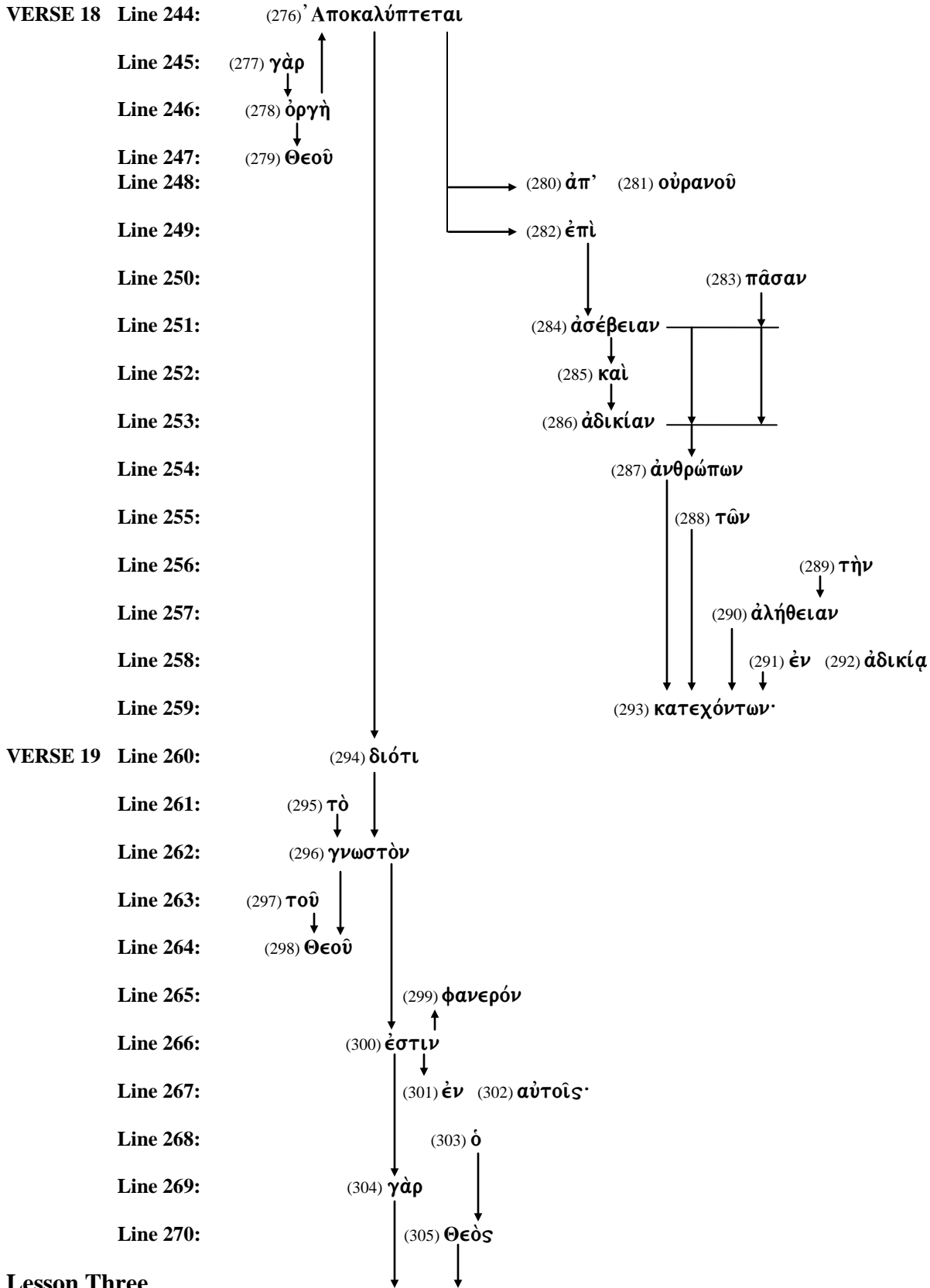

Lesson Three
Romans 1:18-23 Word Association Diagram
Page 80

Romans 1:18-23
Word Association Diagram

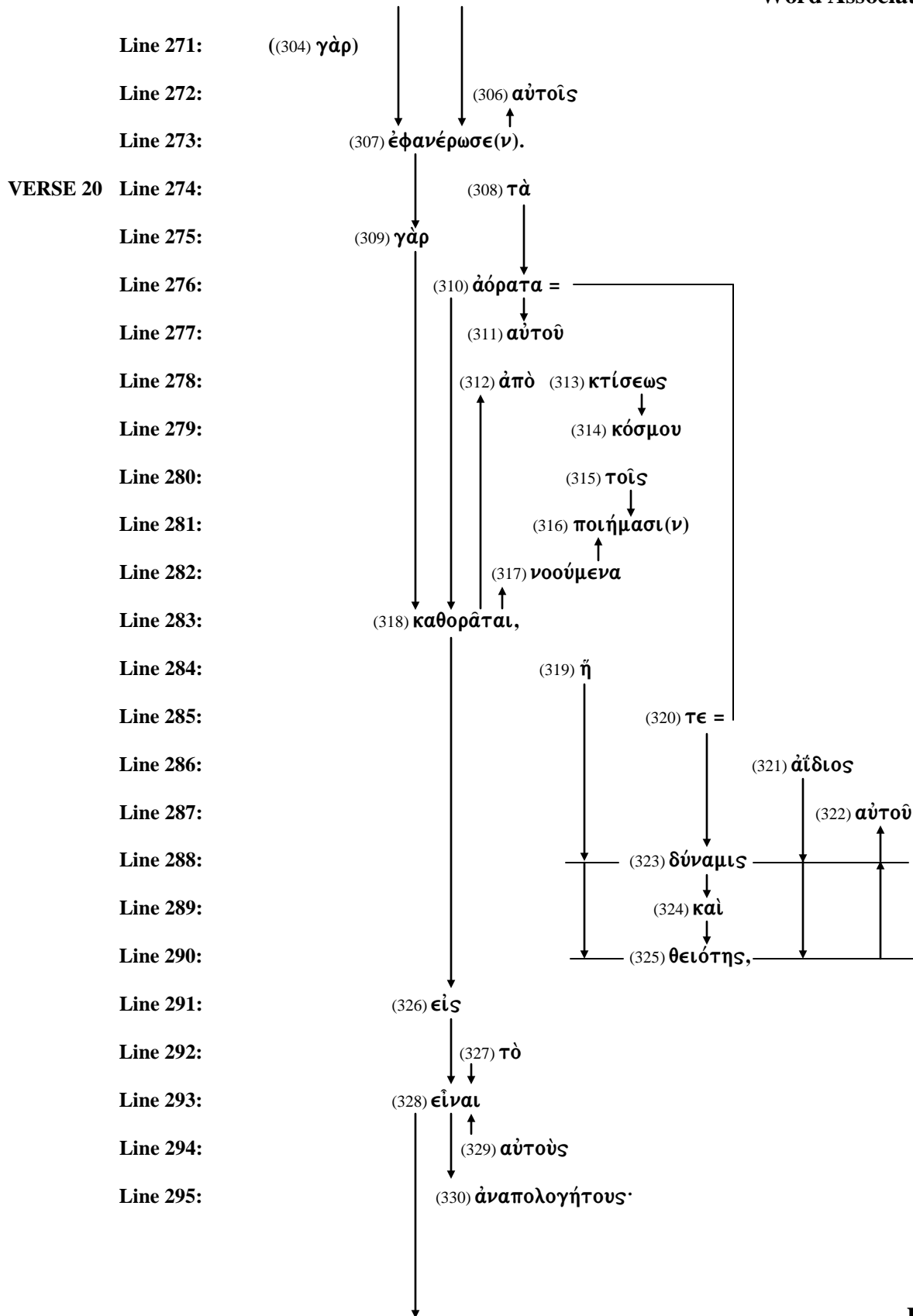

Romans 1:18-23
Word Association Diagram

VERSE 21 Line 296:

Line 297:

Line 298:

Line 299:

Line 300:

Line 301:

Line 302:

Line 303:

Line 304:

Line 305:

Line 306:

Line 307:

Line 308:

Line 309:

Line 310:

Line 311:

Line 312:

Line 313:

Line 314:

Line 315:

Line 316:

VERSE 22 Line 317:

Line 318:

Line 319:

Line 320:

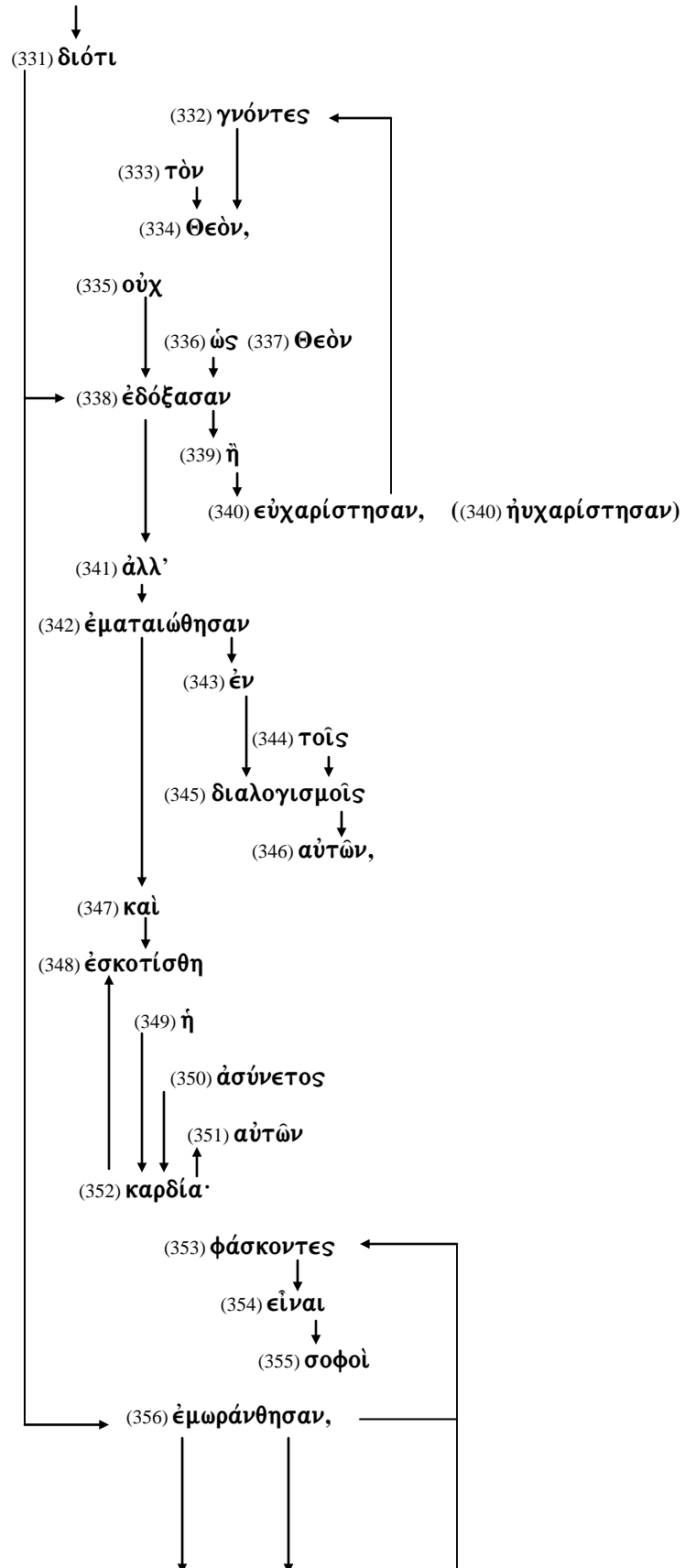

Lesson Three

Romans 1:18-23 Word Association Diagram

VERSE 23 Line 321:
 Line 322:
 Line 323:
 Line 324:
 Line 325:
 Line 326:
 Line 327:
 Line 328:
 Line 329:
 Line 330:
 Line 331:
 Line 332:
 Line 333:
 Line 334:
 Line 335:
 Line 336:
 Line 337:

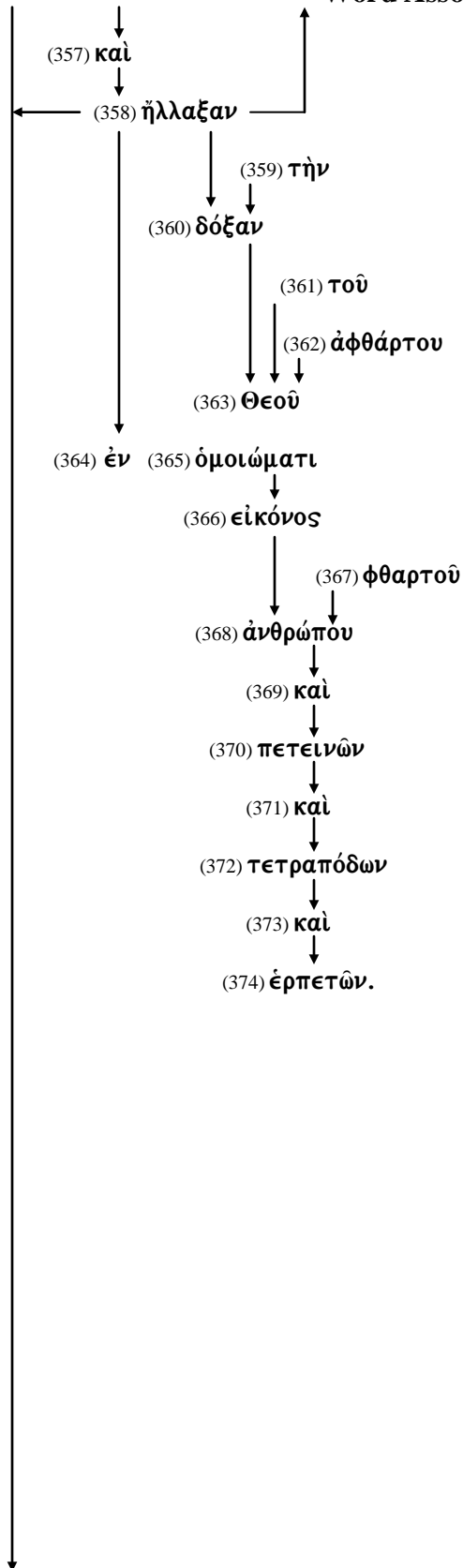

Lesson Three

Romans 1:18-23

Diagrams

Romans 1:18-23
Verse 18 Diagram

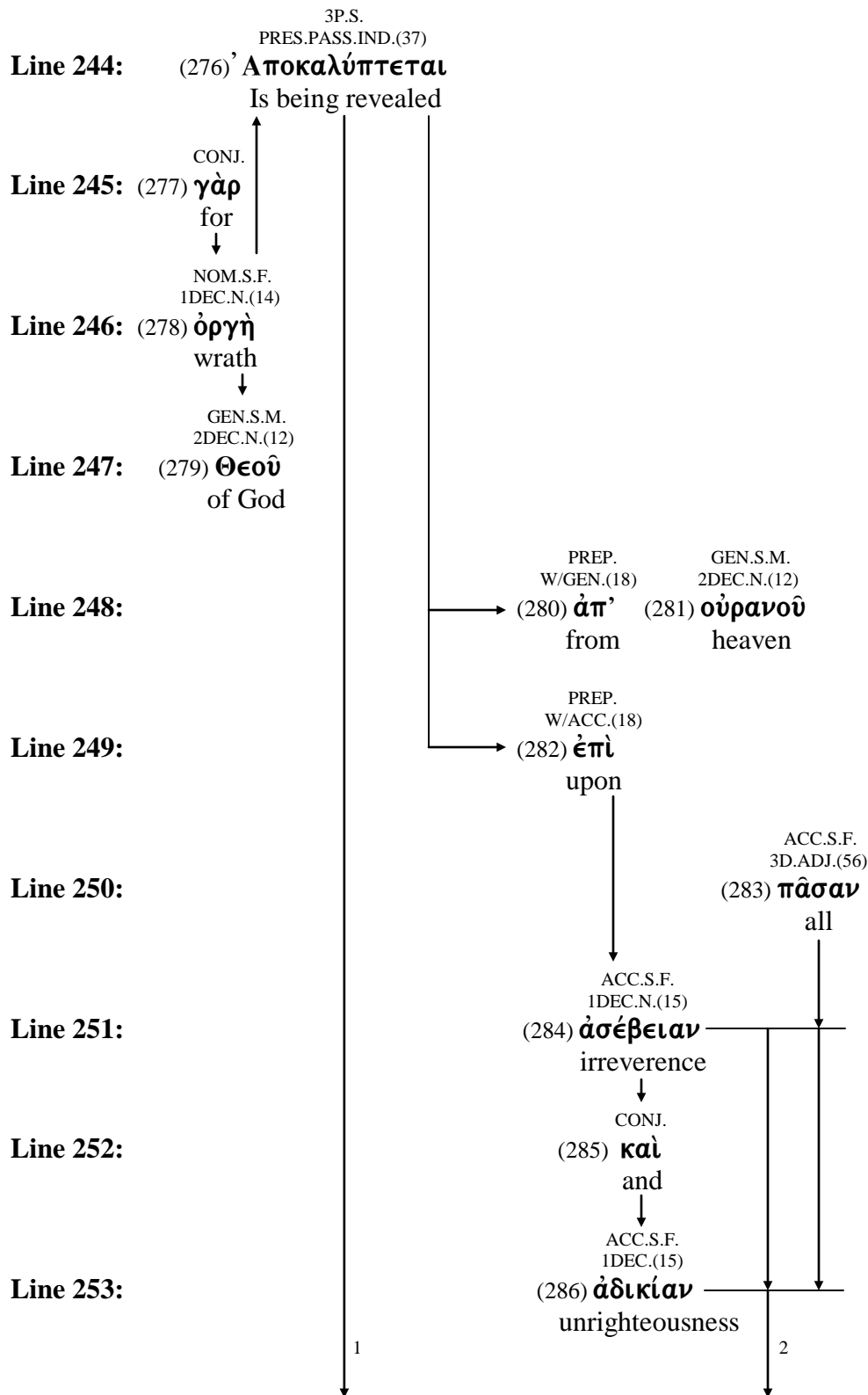

- (276) **ἀποκαλύπτω** = to unveil, to uncover
from **ἀπό** - preposition = from
and **καλύπτω** = to veil, to hide
- (277) **γάρ** - conjunction = for
- (278) **ὀργή** = anger, impulse; any violent expression of emotion
from **ὀρέγω** = to stretch or reach for something
- (279) **θεός** = God, deity
- (280) **ἀπό** - preposition used with the genitive = from, out of
- (281) **οὐρανός** = heaven, sky
- (282) **ἐπί** - preposition used with the accusative = on, to, against
- (283) **πᾶς** - adjective = all, every
- (284) **ἀσέβεια** = ungodliness, irreverence
from **ἀσεβής** - adjective = ungodly
from **α** - alpha privative = without, un-
and **σέβω** = devout
- (285) **καί** - conjunction = and, also, even
- (286) **ἀδικία** = unrighteousness, injustice
from **ἄδικος** - adjective = unjust
from **α** - alpha privative = without, un-
and **δίκη** = justice, sentence, punishment

Continued on page 89.

Romans 1:18-23

Verse 18 Diagram (continued)

Line 254:

↓ 2
GEN.PL.M.
2DEC.N.(12)
(287) **ἀνθρώπων**
of men

Line 255:

GEN.PL.M.
ART.(13)
(288) **τῶν**
the ones

Line 256:

ACC.S.F.
ART.(13)
(289) **τῆν**
the

Line 257:

↓
ACC.S.F.
1DEC.N.(15)
(290) **ἀλήθειαν**
truth

Line 258:

PREP. DAT.S.F.
W/DAT.(18) 1DEC.N.(15)
(291) **ἐν** (292) **ἀδικίᾳ**
in unrighteousness

Line 259:

↓
GEN.PL.
PRES.ACT.PART.(41)
(293) **κατεχόντων**
holding down;

Lesson Three

Romans 1:18 Diagram

- (287) **ἄνθρωπος** = a man, a human being
from **ἄνῆρ** = a male
and **ὄψ** = the face or countenance
- (288) **ὁ** - article = the
- (289) **ὁ** - article = the
- (290) **ἀλήθεια** = truth
from **ἀληθής** - adjective = truth
from **α** - negative particle = without
and **λανθάνω** = to be hidden, to be secret
- (291) **ἐν** - preposition used with the dative = in
- (292) **ἀδικία** = unrighteousness, injustice
from **ἄδικος** - adjective = unjust
from **α** - alpha privative = without, un-
and **δίκη** = justice, sentence, punishment
- (293) **κατέχω** = to hold down, possess, to suppress
from **κατὰ** - preposition used with the genitive = down, against
and **ἔχω** = to have, to hold

Romans 1:18-23
Verse 19 Diagram

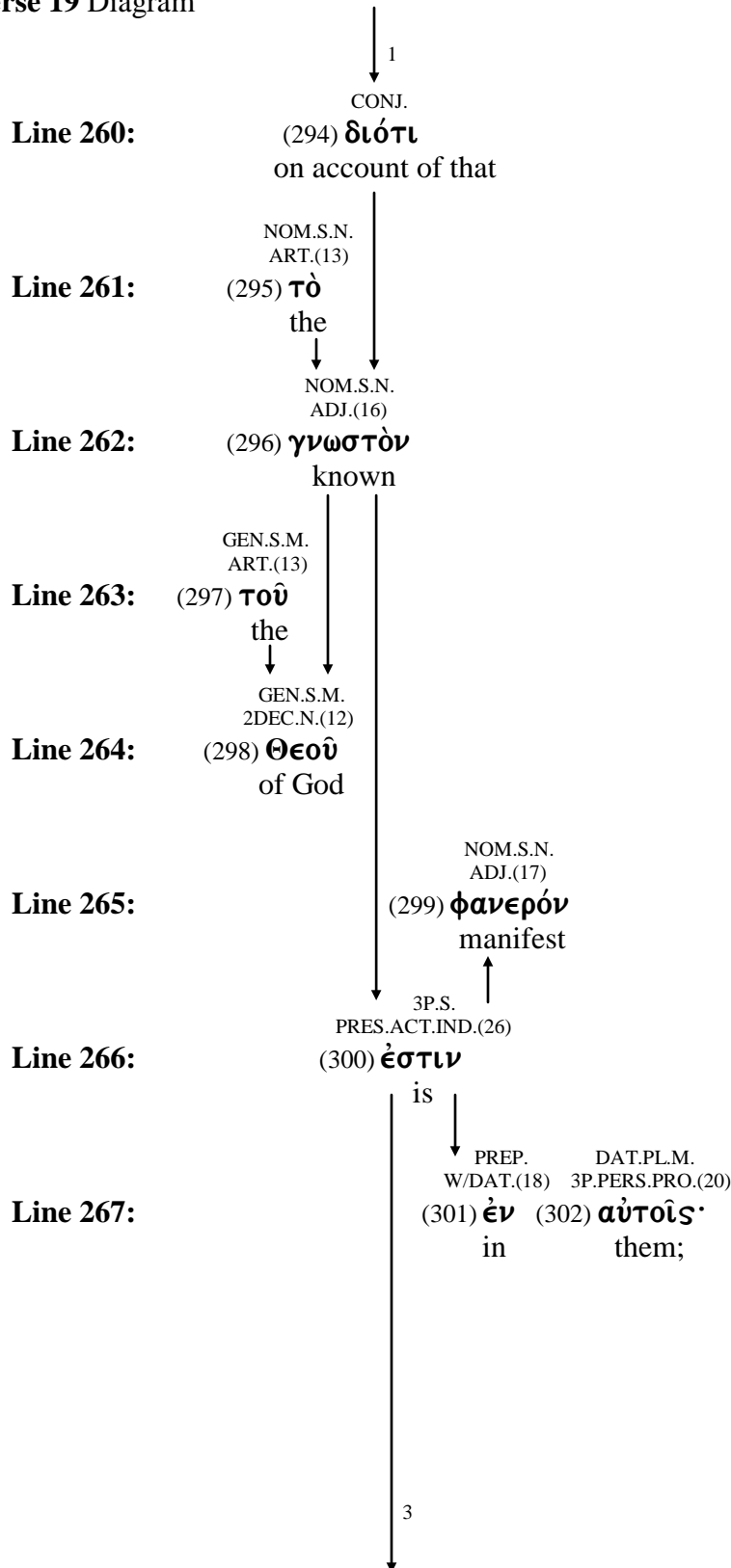

- (294) **διότι** - conjunction = on account of
from **διά** - preposition = on account of
and **ὅτι** - conjunction = that
- (295) **ὁ** - article = the
- (296) **γνωστός** - adjective = known, knowable
from **γινώσκω** = to know
- (297) **ὁ** - article = the
- (298) **θεός** = God, deity
- (299) **φανερός** - adjective - manifest, evident, apparent
from **φαίνω** = to shine, to make appear in the light
from **φῶς** = light
- (300) **εἰμί** = to be, exist
- (301) **ἐν** - preposition used with the dative = in
- (302) **αὐτός** - third person personal pronoun = he, she, it

Continued on page 93.

Romans 1:18-23

Verse 19 Diagram (continued)

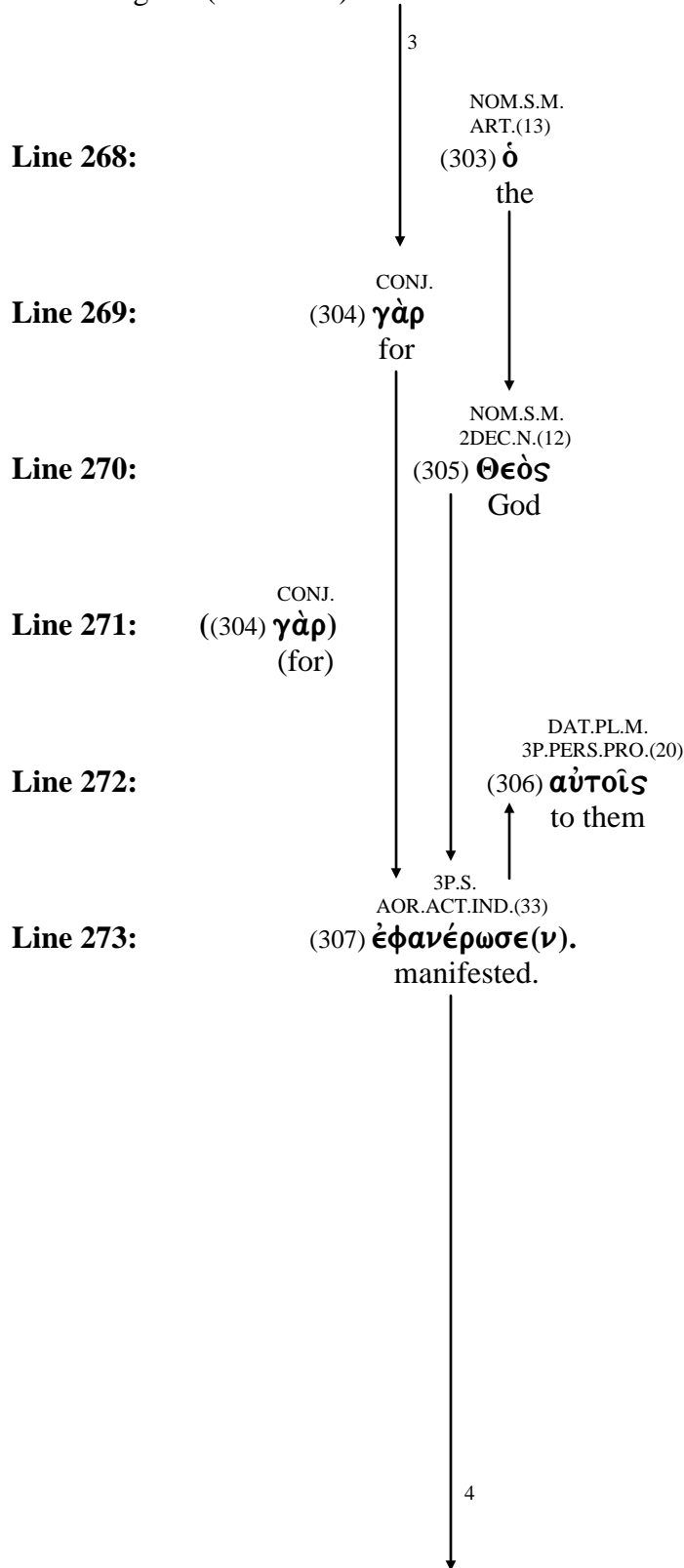

Lesson Three

Romans 1:19 Diagram

(303) **ὁ** - article = the

(304) **γάρ** - conjunction = for

(305) **θεός** = God, deity

(306) **αὐτός** - third person personal pronoun = he, she, it

(307) **φανερῶ** = to make manifest, to make visible

from **φανερός** - adjective - manifest, evident, apparent

from **φαίνω** = to shine, to make appear in the light

from **φῶς** = light

Romans 1:18-23
Verse 20 Diagram

Line 274:

NOM.PL.N.
 ART.(13)
 (308) **τὰ**
 the things

Line 275:

CONJ.
 (309) **γὰρ**
 for

Line 276:

NOM.PL.N.
 3D.ADJ.(56)
 (310) **ἀόρατα** =
 invisible

Line 277:

GEN.S.M.
 3P.PERS.PRO.(20)
 (311) **αὐτοῦ**
 of him

Line 278:

PREP.
 W/GEN.(18) GEN.S.F.
 3DEC.N.(39)
 (312) **ἀπὸ** (313) **κτίσεως**
 from creation

Line 279:

GEN.S.M.
 2DEC.N.(12)
 (314) **κόσμου**
 of world

Line 280:

DAT.PL.N.
 ART.(13)
 (315) **τοῖς**
 the things

Line 281:

DAT.PL.N.
 3DEC.N.(40)
 (316) **ποιήμασι(ν)**
 being made

Line 282:

NOM.PL.N.
 PRES.MID.PART.(42)
 (317) **νοούμενα**
 being perceived

Line 283:

3P.S.
 PRES.MID.IND.(23)
 (318) **καθορᾶται,**
 are being clearly seen,

- (308) **ὁ** - article = the
- (309) **γάρ** - conjunction = for
- (310) **ἀόρατος** - adjective = invisible, unseen
from **α** - negative particle = without, un-, in-
and **όρατός** - adjective = visible, able to see
from **όράω** = to see with the eyes, to see with the mind, to perceive.
- (311) **αὐτός** - third person personal pronoun = he, she, it
- (312) **ἀπό** - preposition used with the genitive = from, out of
- (313) **κτίσις** = the act of creating, the thing created
from **κτίζω** = to create
- (314) **κόσμος** = world; arrangement, order decoration
- (315) **ὁ** - article = the
- (316) **ποίημα** = a work, what has been made, workmanship
from **ποιέω** = to make
- (317) **νοέω** = to perceive, to understand
from **νοῦς** = the mind, the faculties of perceiving
- (318) **καθοράω** = to see clearly, to notice, to view
from **κατά** - preposition = down, according to
and **όράω** = to see, to behold
from **όπτάνομαι** = to appear

Continued on page 97.

Romans 1:18-23

Verse 20 Diagram (continued)

Line 284:

NOM.S.F.
ART.(13)
(319) ἡ
the

Line 285:

CONJ.
(320) τε
both

Line 286:

NOM.S.F.
3D.ADJ.(56)
(321) αἰδιος
eternal

Line 287:

GEN.S.M.
3P.PERS.PRO.(20)
(322) αὐτοῦ
of Him

Line 288:

NOM.S.F.
3DEC.N.(39)
(323) δύναμις
power

Line 289:

CONJ.
(324) και
and

Line 290:

NOM.S.F.
3DEC.N.(39)
(325) θειότης,
divinity,

Line 291:

PREP.
W/ACC.(18)
(326) εις
for

Line 292:

ACC.S.N.
ART.(13)
(327) τὸ
the

Line 293:

PRES.ACT.INF.(26)
(328) εἶναι
to be

Line 294:

ACC.PL.M.
3P.PERS.PRO.(20)
(329) αὐτούς
them

Line 295:

ACC.PL.M.
3D.ADJ.(56)
(330) ἀναπολογήτους·
without excuse:

- (319) **ὁ** - article = the
- (320) **τε** - particle of connection or addition = and, also, both
- (321) **αἰδιος** - adjective = eternal, everlasting
from **αἰεί** - adverb = always, for ever
- (322) **αὐτός** - third person personal pronoun = he, she, it
- (323) **δύναμις** = strength, power, ability
from **δύναμαι** = ability, power
- (324) **καί** - conjunction = and, also, even
- (325) **θειότης** = divinity
from **θεῖος** - adjective = divine
from **θεός** = God, god, a deity
- (326) **εἰς** - preposition used with the accusative = to, unto, towards
- (327) **ὁ** - article = the
- (328) **εἰμί** = to be, exist
- (329) **αὐτός** - third person personal pronoun = he, she, it
- (330) **ἀναπόλογη** - adjective = without a defense, without excuse
from **α** - alpha privative = without, un-
and **ἀπολογέομαι** = defense, excuse
from **ἀπό** - preposition = from
and **λόγος** = word
from **λέγω** = to say

Romans 1:18-23
Verse 21 Diagram

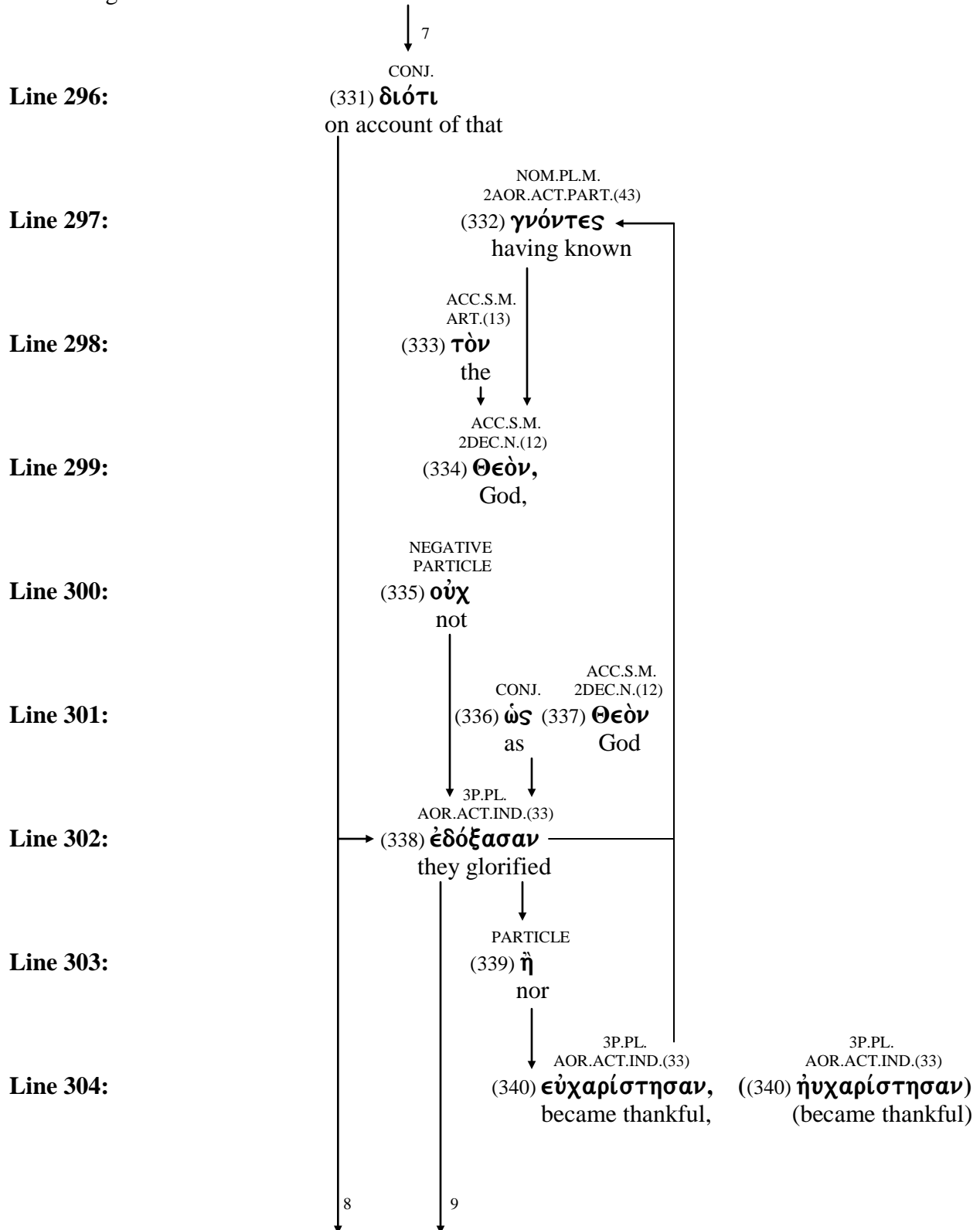

- (331) **διότι** - conjunction = on account of
from **διά** - preposition = on account of
and **ὅτι** - conjunction = that
- (332) **γινώσκω** = to know
- (333) **ὁ** - article = the
- (334) **θεός** = God, deity
- (335) **οὐ** - negative particle = no, not
- (336) **ὡς** - adverb used as a comparative particle = as, like
from **ὅς** - relative pronoun = who, which, what
- (337) **θεός** = God, deity
- (338) **δοξάζω** = to give glory
from **δόξα** = glory
from **δοκέω** = to think, to give an opinion
- (339) **ἢ** - particle used as a conjunction = or
- (340) **εὐχαριστέω** = to be thankful, grateful
from **εὐχάριστος** - adjective = thankful
from **εὖ** - adverb = to be well, prosper
and **χαρίζομαι** = to favor, to forgive
from **χάρις** = grace

Continued on page 101.

Romans 1:18-23
Verse 21 Diagram

Line 305:

8
 9
 CONJ.
 (341) **ἀλλ'**
 but

Line 306:

3P.PL.
 AOR.PASS.IND.(37)
 (342) **ἐματαιώθησαν**
 became empty

Line 307:

PREP.
 W/DAT.(18)
 (343) **ἐν**
 in

Line 308:

DAT.PL.M.
 ART.(13)
 (344) **τοῖς**
 the

Line 309:

DAT.PL.M.
 2DEC.(12)
 (345) **διαλογισμοῖς**
 reasonings

Line 310:

GEN.PL.M.
 3P.PERS.PRO.(20)
 (346) **αὐτῶν,**
 of them,

8

10

- (341) **ἀλλά** - conjunction = but
- (342) **ματαιόω** = to make empty or vain
from **μάταιος** - adjective = empty, vain
from **μάτην** - adverb = vainly
- (343) **ἐν** - preposition used with the dative = in
- (344) **ὁ** - article = the
- (345) **διαλογισμός** = to think through, thought, reasoning, deliberating
from **διαλογίζομαι** = to reason, to deliberate
from **διά** - preposition = through
and **λογίζομαι** = to reason, to calculate,
from **λόγος** = word, speech
- (346) **αὐτός** - third person personal pronoun = he, she, it

Continued on page 103.

Romans 1:18-23

Verse 21 Diagram (continued)

Line 311:

8
10
↓
CONJ.
(347) **καὶ**
and
↓

Line 312:

3P.S.
AOR.PASS.IND.(37)
(348) **ἐσκοτίσθη**
was darkened

Line 313:

NOM.S.F.
ART.(13)
(349) **ἡ**
the

Line 314:

NOM.S.F.
3D.ADJ.(56)
(350) **ἀσύνετος**
without understanding

Line 315:

GEN.PL.M.
3P.PERS.PRO.(20)
(351) **αὐτῶν**
of them

Line 316:

NOM.S.F.
1DEC.N.(15)
(352) **καρδία·**
heart;

8
↓

Lesson Three

Romans 1:21 Diagram

Page 102

- (347) **καί** - conjunction = and, also, even
- (348) **σκοτίζω** = to make dark
from **σκότος** - adjective = dark
from **σκιά** = shadow
- (349) **ὁ** - article = the
- (350) **ἀσύνετος** = without understanding
from **α** - alpha privative = without, un-
and **συνετός** - adjective = prudent
from **συνίημι** = to understand
from **σύν** - preposition = with
and **ἵημι** = to send
- (351) **αὐτός** - third person personal pronoun = he, she, it
- (352) **καρδία** = heart

Romans 1:18-23
Verse 22 Diagram

Line 317:

NOM.PL.M.
 PRES.ACT.PART.(41)
 (353) **φάσκοντες**
 professing

Line 318:

PRES.ACT.INF.(26)
 (354) **εἶναι**
 to be

Line 319:

NOM.PL.M.
 ADJ.(17)
 (355) **σοφοὶ**
 wise

Line 320:

3P.PL.
 AOR.PASS.IND.(37)
 (356) **ἐμωράνθησαν,**
 they became fools,

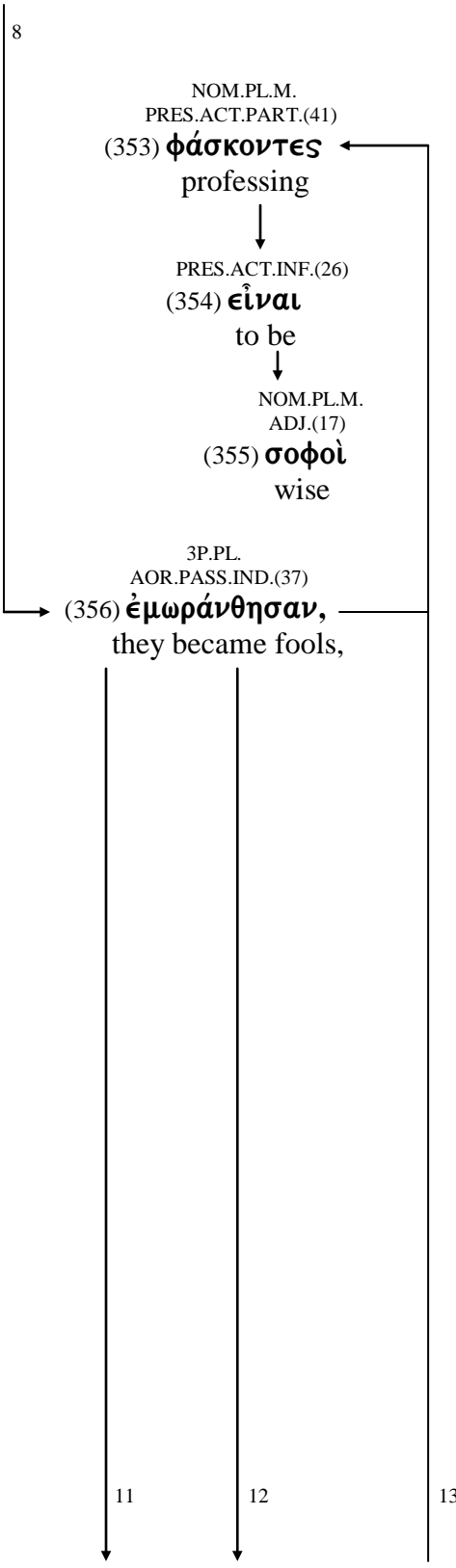

- (353) **φάσκω** = to affirm, alledge
from **φημί** = to say, to affirm
from **φῶς** = light
from **φαίνω** = to appear, to shine
- (354) **εἶμί** = to be, exist
- (355) **σοφός** - adjective = wise
- (356) **μωραίνω** = to make foolish
from **μωρός** - adjective = foolish

- (357) **καί** - conjunction = and, also, even
- (358) **ἀλλάσσω** = to change
from **ἄλλος** - adjective = another
- (359) **ὁ** - article = the
- (360) **δόξα** = glory, honor; opinion, judgment, view
from **δοκέω** = to think, suppose, presume; to have an opinion of
- (361) **ὁ** - article = the
- (362) **ἀφθαρτός** - adjective = incorruptible, imperishable
from **α** - alpha privative - without, un-
and **φθείρω** = to corrupt, to defile
- (363) **θεός** = God, deity

Continued on page 109.

Romans 1:18-23

Verse 23 Diagram (continued)

Line 328:

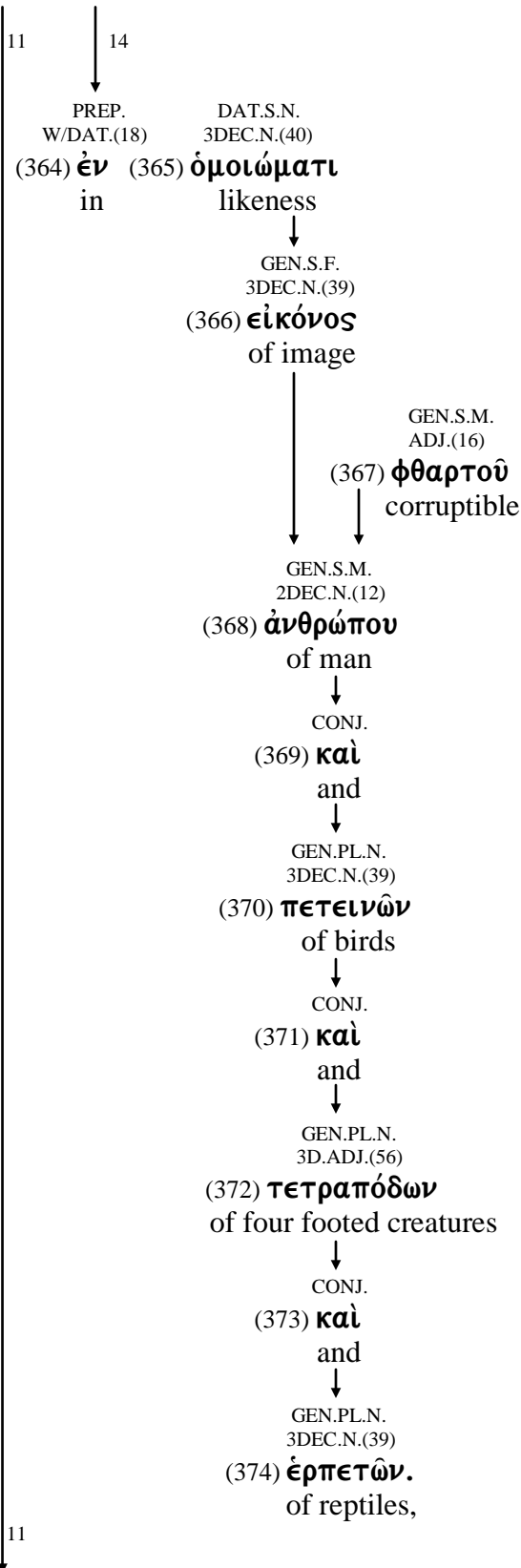

Line 329:

Line 330:

Line 331:

Line 332:

Line 333:

Line 334:

Line 335:

Line 336:

Line 337:

- (364) **ἐν** - preposition used with the dative = in
- (365) **ὁμοίωμα** = likeness, image, copy
from **ὁμοίω** = to make like
from **ὅμοιος** = like
from **ὁμοῦ** - adverb = together
- (366) **εἰκών** = image, likeness, appearance
from **εἶκα** = to make like
from **εἶκω** = to yield, to give place to
- (367) **φθαρτος** - adjective = incorruptible, imperishable
from **φωείρω** = to corrupt, to defile
- (368) **ἄνθρωπος** = a man, a human being
from **ἄνῆρ** = a male
and **ὄψ** = the face or countenance
- (369) **καί** - conjunction = and, also, even
- (370) **πετεινόν** = a bird
from **πέτομαι** = to fly
- (371) **καί** - conjunction = and, also, even
- (372) **τετράπους** - adjective = four-footed
from **τέσσαρες** = four
and **πούς** = foot
- (373) **καί** - conjunction = and, also, even
- (374) **έρπετόν** = creeping thing, reptile, snake
from **έρπω** = to creep

